

## Operation and Maintenance Manual

### Residential Systems CE and CEN Models

Rev. 6/24/19

**Please Note:**  
Product warranty requires proper system operation  
and maintenance as described in this Manual.



Certified to  
NSF/ANSI Standards 40 & 245



## Operation and Maintenance Manual – Residential Systems

### Introduction

This manual describes operation and maintenance (O&M) procedures necessary to assure proper function and operation of Fuji Clean USA wastewater treatment systems, including start-up and routine procedures. The manual is divided into the following sections:

#### Sections

1. Installation Overview.....	Page 3
2. Treatment Process Overview.....	Page 4
3. System Components and Specifications	
a. Summary .....	Page 5
b. FujiMACR11 Blowers.....	Page 6
c. Alarm Panel .....	Page 8
d. Float Switch .....	Page 12
e. Wi-Fi Communication Device .....	Page 13
4. Maintenance Program with Scheduled Maintenance Procedures.....	Page 15
5. System Inspection Checklist .....	Page 22
6. Troubleshooting Guide.....	page 23

# Installation Overview

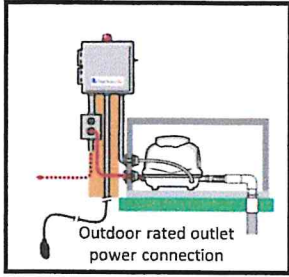

System Controller/Alarm (supplied by Fuji Clean USA) Suffolk County requires FujiMACR11 series blower power connection to be hardwired to control panel.

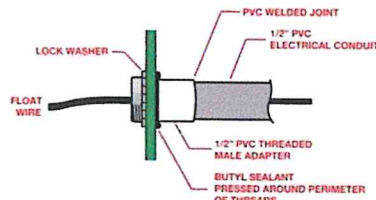
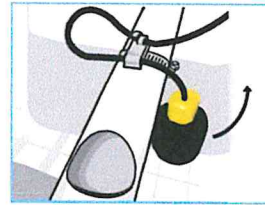
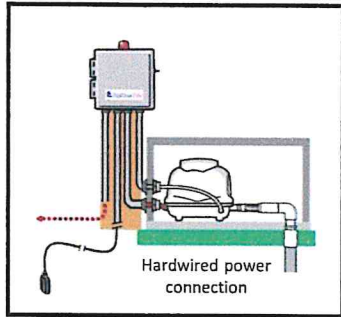

For connection of SJE Rhombus Signalmaster float switch cord to alarm panel, drill hole in riser and use male fitting and electrical conduit. Plug fitting with sealant standard that meets ASTM C990-96 to assure water-tight seal and to prevent septic gas transmission into control panel. Install on the pumpback line using the provided hose clamp and mounting fixture in the center of Chamber 2, (Anaerobic Contact Filtration Chamber) with 3-1/2" (9 cm) of electrical cord tether.

System vents through house vent system. For houses with house traps installed, vent system separately through vent hole.

For connection air line to tank, use Fuji Clean supplied tank adaptor and either 3/4" or 1" conduit or flexible pipe. Air line should be less than 100' and have 5 or fewer "elbows." (If site conditions will not allow, please contact Fuji Clean for blower upsize calculation.)

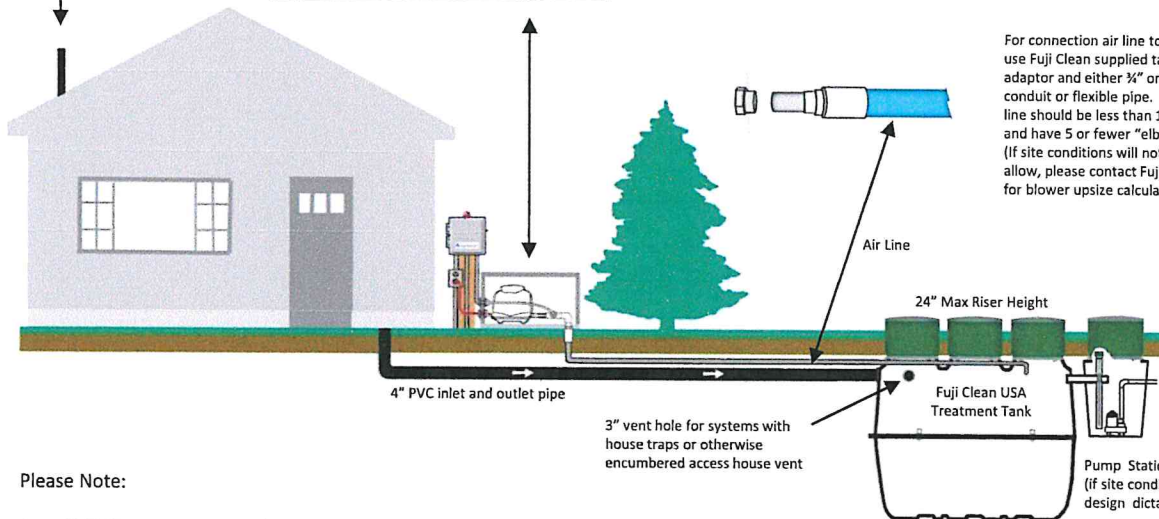

**Please Note:**

1. Fuji Clean systems are designed to accept straight septic wastewater and do not require a preceding septic or settling tank
2. "Clearwater" water softener backwash should be discharged directly to a separate drywell or leaching pool.

Using grommets or a waterproof adhesive, labels meeting NSF standards (supplied by Fuji Clean USA) shall be affixed in two locations, inside the inlet riser and on the inside of the controller.

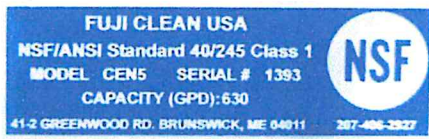

Sample Label



## Section 2. Treatment Process Overview

Fuji Clean's "contact filtration" treatment is a simple, well engineered process that consists of a controlled, circuitous flow train through anaerobic and aerobic chambers and in direct contact with assorted proprietary fixed film medias on which biological digestion of organic matter occurs. Media is also designed and positioned to provide mechanical filtration of process wastewater.

The system includes two air lift pumps (see diagram below) The Recirculating Airlift Pump returns process water and sludge from the aerobic zone to the sedimentation chamber, recirculating 2-4 times inflow per day for CE models and 4-6 times inflow for CEN (enhanced denitrification) models. The Effluent Airlift Pump is designed to help equalize flow and discharge treated effluent.

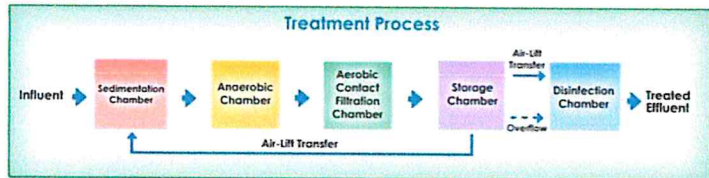

**Two Air Lift Pumps.** One Recirculating Air Lift pump sending process water and solids back to Chamber 1, and one Effluent Air Lift Pump for measured discharge of treated effluent. (See airlift pump info below).

**Chamber 3B. Disinfection Chamber** (final zone before discharge – option for chlorination tablet disinfection)

**Chamber 3A. Storage Chamber** (settling zone)

**Sludge Transfer**  
(Recirculating air lift pumpback) See airlift pump info below.

Outlet

Inlet

**Powered by the FujiMACR11 Series Blowers** State-of-the-art linear diaphragm air blowers manufactured by Fuji Clean Co sized to provide about 2.8 cubic feet per minute to most residential systems.

**Chamber 3. Aerobic Contact Filtration Chamber** (both board and cylindrical hollow mesh media) oxygen rich zone for aerobic microbe digestion activity, solids filtration and nitrification of ammoniac nitrogens to nitrates

**Chamber 2. Anaerobic Contact Filtration Chamber** (spherical-skeleton filter media) organic matter decomposition by micro-organisms, suspended solids captured and nitrates are denitrified

**Chamber 1. Sedimentation Chamber** (separates solids and greases)

Overflow Effluent Weir

**Flow Equalization**

When water level exceeds LWL, treated water is discharged through Chamber 3B via the Effluent Air Lift pump. If water level exceeds HWL, then treated water is also discharged through an overflow effluent weir.

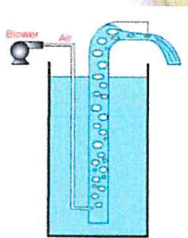

**Airlift Pumps.** This generic illustration shows the mechanics of the "airlift pumps" used in this system, which are simple pipe conduits through which pressurized air (from blower) is introduced at the bottom and by fluid pressure, water is carried up the pipe by ascending bubbles.

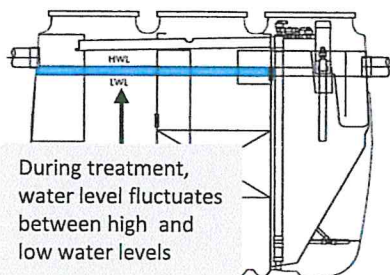

During treatment, water level fluctuates between high and low water levels

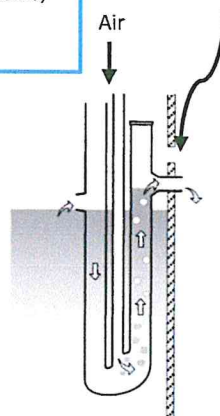

## Section 3a. System Components and Specifications - Summary

FUJI CLEAN USA RESIDENTIAL SYSTEM SPECIFICATION TABLE		CE Series BOD, TSS, TN*				CEN Series BOD, TSS, Enhanced TN		
Model	CE5	CE7	CE10	CE14	CEN5	CEN7	CEN10	
Load Hydraulic** (GPD)	500	700	900	1000	500	700	900	
Effluent*** (assumes domestic strength influent)								
BOD (mg/L)	10-20	10-20	10-20	10	10	10	10	
TSS (mg/L)	10-20	10-20	10-20	10	10	10	10	
TN (mg/L)	10-20	10-20	10-20	10	10	10	10	
Blower Model / CFM (Standard)	FujiMAC 80RII 2.8 CFM	FujiMAC 80RII 2.8 CFM	FujiMAC 100RII 3.5 CFM	FujiMAC 100RII 3.5 CFM	FujiMAC 80RII 2.8 CFM	FujiMAC 100RII 2.8 CFM	FujiMAC 100RII 3.5 CFM	
Power Use (kWh/day)	1.2	1.2	1.7	1.7	1.2	1.7	1.7	
Tank Detail:								
Material	Fibre-reinforced plastic				Fibre-reinforced plastic			
Height (inches)	61.8	65.4	73.2	77.4	65.4	73.2	77.4	
Length (inches)	85	95.7	98.8	118.9	95.7	98.8	118.9	
Width (inches)	43.7	49.2	56.7	68.9	49.2	56.7	68.9	
Weight (lbs.)	397	463	705	926	463	705	926	
Inlet Invert (inches, to 1/8")	49	53	61	62	53	61	62	
Outlet Invert (inches to 1/8")	47	51	59	59.5	51	59	59.5	
Access Ports (number)	3	3	3	3	3	3	3	
Access Port Diameter (inches)	3@20"	2@20" 1@24"	2@20" 1@24"	2@20" 1@24"	2@20" 1@24"	2@20" 1@24"	2@20" 1@24"	
Volume Total (gallons)	540	749	1069	1498	749	1069	1498	
Volume Chamber 1, Sedimentation (gal)	198	277	397	558	277	397	558	
Vol Chamber 2, Anaerobic (gal)	198	278	396	556	278	396	556	
Vol Chamber 3, Aeration (gal)	95	127	181	248	127	181	248	
Vol Chamber 3a, Storage (gal)	44	63	90	124	63	90	124	
Volume Chamber 3b, Disinfection (gal)	4	4	6	12	4	6	12	

\* TN data was obtained during CE testing, but not to NSF245 testing protocol. CEN testing was to NSF245 protocol.

\*\* Please consult with distributor or Fuji Clean USA for commercial models designed to treat hydraulic flows above those listed in this table.

\*\*\* Please consult with distributor or Fuji Clean USA for system specification and sizing in cases where influent biologic strength is greater than domestic strength.

Note: Structural drawings of all residential models are available in both .dwg and pdf formats online at [www.fujicleanusa.com](http://www.fujicleanusa.com)

## Section 3b. System Components – FujiMACR11 Blowers

The Table below includes specifications for FujiMACR11 series blowers. The table below includes blower models associated with each standard system installation. Some installations may require upsized blowers based on overall distance (i.e. air conduit length and diameter) and number of elbows from blower to treatment system. Please refer to Fuji Clean installation guidelines.

Fuji Clean USA Treatment System Model	CE5 CE7 CEN5	CE10 CE14 CEN7 CEN10	CEN10 CE30 (x2) CEN21 (x2)	CE21 CEN14
MACBlower Model	FujiMAC 80R11	FujiMAC 100R11	FujiMAC 150R11	FujiMAC 200R11
Air Flow Volume	80 L/min 2.8 cfm	100 L/min 3.5 cfm	150 L/min 5.3 cfm	200 L/min 7.0 cfm
Normal Pressure	15 kPa 2.2 psi	18 kPa 2.6 psi	18 kPa / 2.6 psi	
Rated Voltage	120V			
Frequency	60Hz			
Outlet Pipe Size	13mm ID (18mm OD) 33/64 inch ID (45/64 inch OD)		20mm ID (26mm OD) 25/32 inch ID (1-1/32 inch OD)	
Weight	5.0kg 11 lbs.		9.0kg 19 lbs. 13 oz.	
Power Consumption kWh/day	1.2	1.7	2.7	3.7
Amperes	1.0A	1.7A	2.3A	3.1A
Power Cable	3 × 18AWG × 1.8m (5ft.11in.)			
Manufacturer	Made in Japan by Fuji Clean			

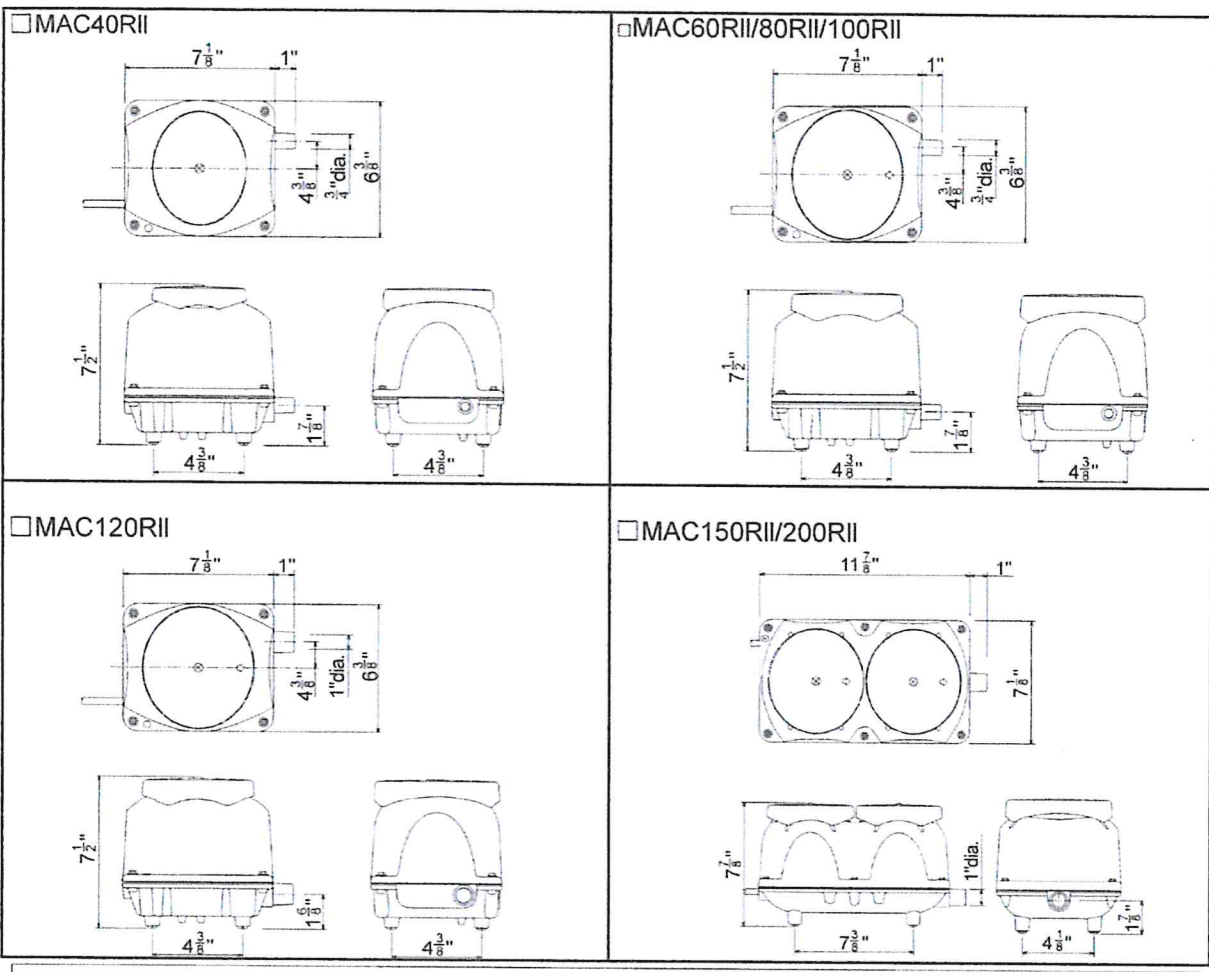

**FujiMAC Series Performance Curve -120V60Hz**  
 MAC40R II /60R II /80R II /100R II /120R II /150R II /200R II

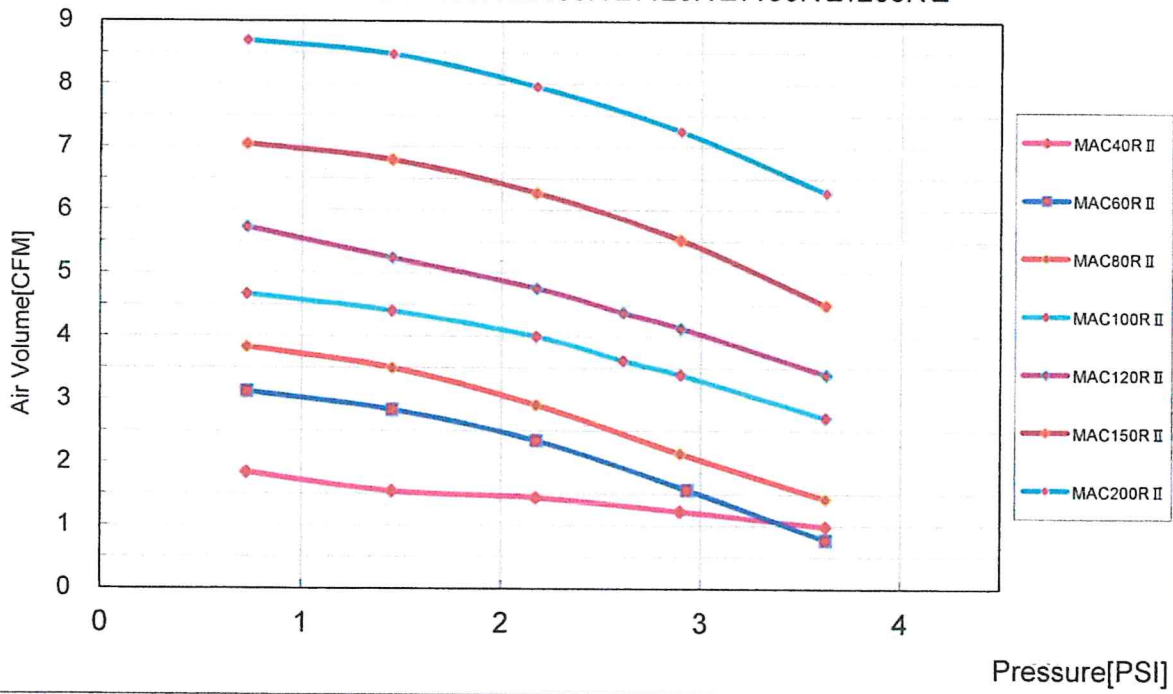

## Section 3c. System Components - Alarm / Control Panel

NEMA 4X rated, the Alarm/Control Panel monitors tank water level and blower operation. An audible horn and red beacon light will activate in the event of either a tank high water condition or if the blower ceases to operate (causing a drop in air pressure). Please note: upgraded controllers with telecommunication, alarm tracking and data logging capabilities are available.

A 3-way toggle switch (Test-Normal-Silence) allows check for proper operation by toggling the side panel switch to “Test” mode. When switch is released, it will return to normal operation.

In the event of an alarm condition the “Silence” switch may be engaged to silence the audible alarm. The beacon will continue to flash until normal operation is restored and the alarm will reset. If a new alarm condition occurs, the “Silence” mode will expire and the unit’s horn will begin sounding again.

All conduits between panel and treatment tank must be sealed to prevent gas leakage into panel.

Fuji Clean USA offers a choice of customized alarm/control panels, each with different features. Control panel customization is also available to match unique site or job requirements. Please consult Fuji Clean USA for details.

Model Features	Controller A	Controller C	Controller D	Controller E
SJE Rhombus Model #	1041972	1045040	IFS41W914X6A8AC10E27D	IFI41W914X6A8AC10E27D
NEMA 4X Weather Proof Enclosure	X	X	X	X
Three 120 Volt AC Breakers (Pump, Compressor, Alarm)	X	X	X	X
Alarm/Test/Normal/Silence Switch	X	X	X	X
Compressor Low Pressure Alarm Switch	X	X	X	X
Communication Contacts (Alarm Aux)		X	X	X
Elapsed Time Meter		X	X	X
Duplex Pump Demand or Timed Dosing Control			X	X
Data Logging Panel via USB Port to Flash Drive				X
UL Listed to Meet and/or Exceed Industry Safety Standards			X	X
Dual Safety Certification for U.S and Canada			X	X



Fuji Clean USA  
Controller "A"

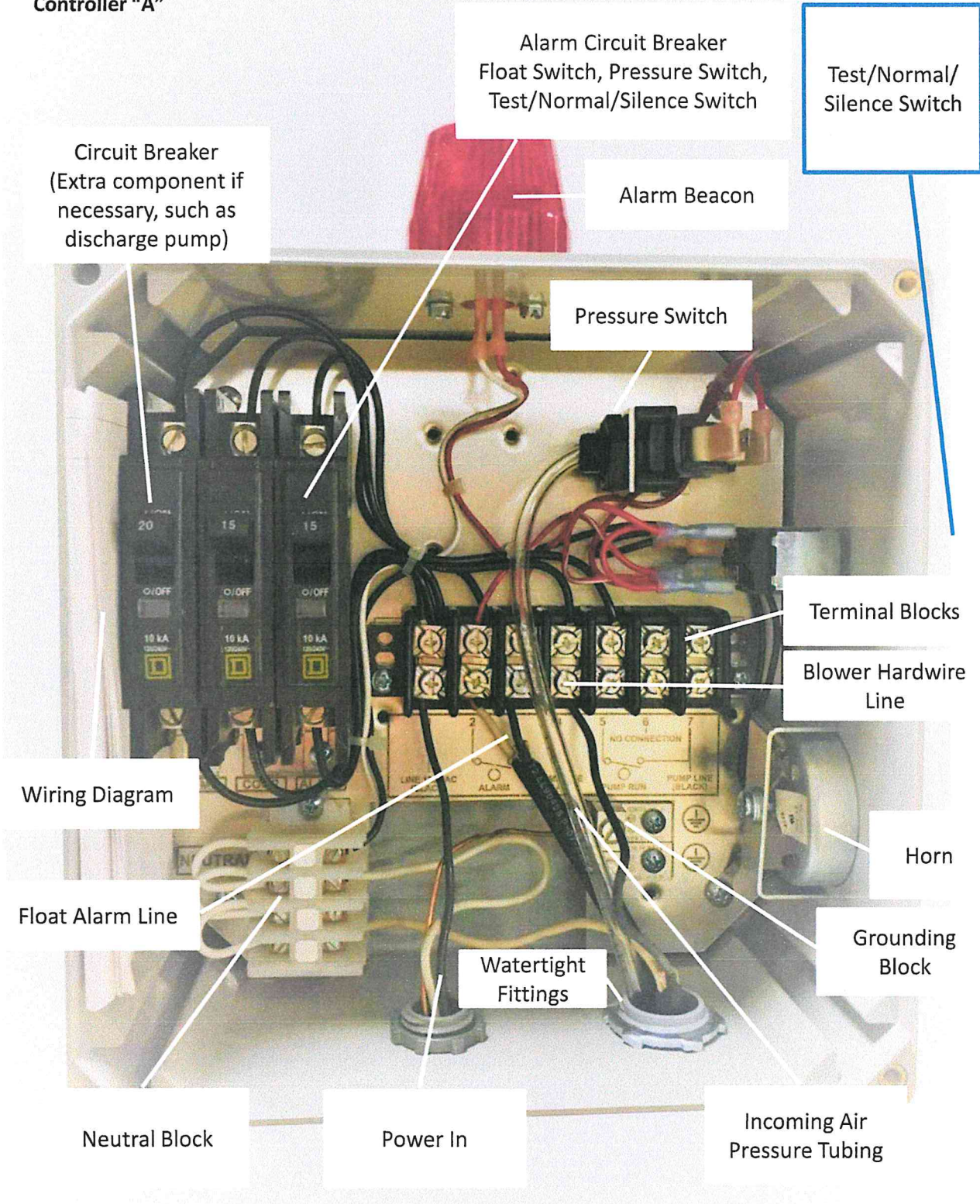

# Controller "A" Wiring Diagram

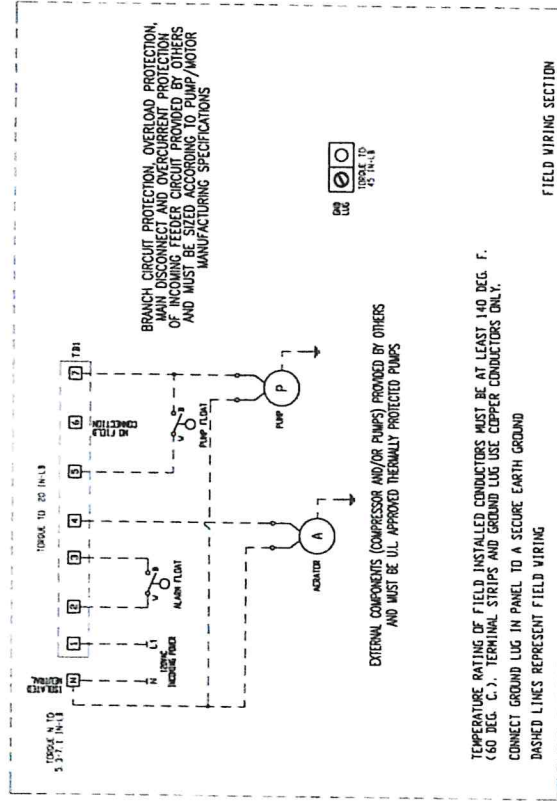
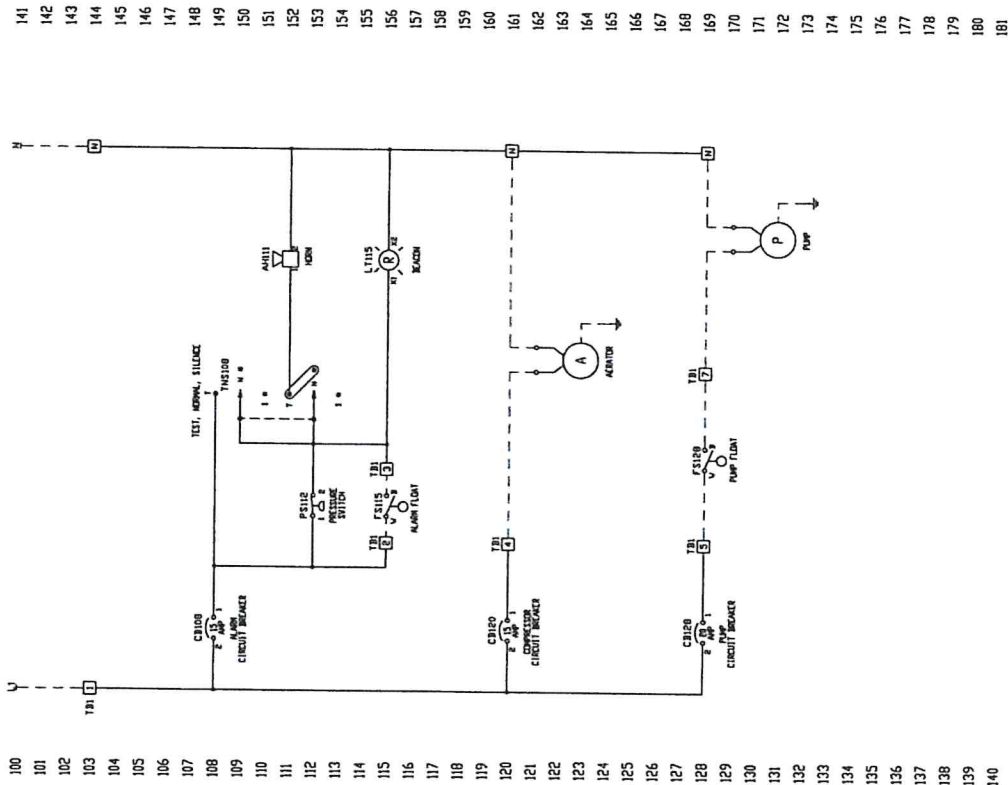

SPECIFICATIONS		MATERIALS		DIMENSIONS		WEIGHTS	
ITEM NO.	DESCRIPTION	QTY	UNIT	INCHES	FEET	POUNDS	GRAMS
1	...	...	...	...	...	...	...
2	...	...	...	...	...	...	...
3	...	...	...	...	...	...	...
4	...	...	...	...	...	...	...
5	...	...	...	...	...	...	...
6	...	...	...	...	...	...	...
7	...	...	...	...	...	...	...
8	...	...	...	...	...	...	...
9	...	...	...	...	...	...	...
10	...	...	...	...	...	...	...

# Controller "C" Wiring Diagram

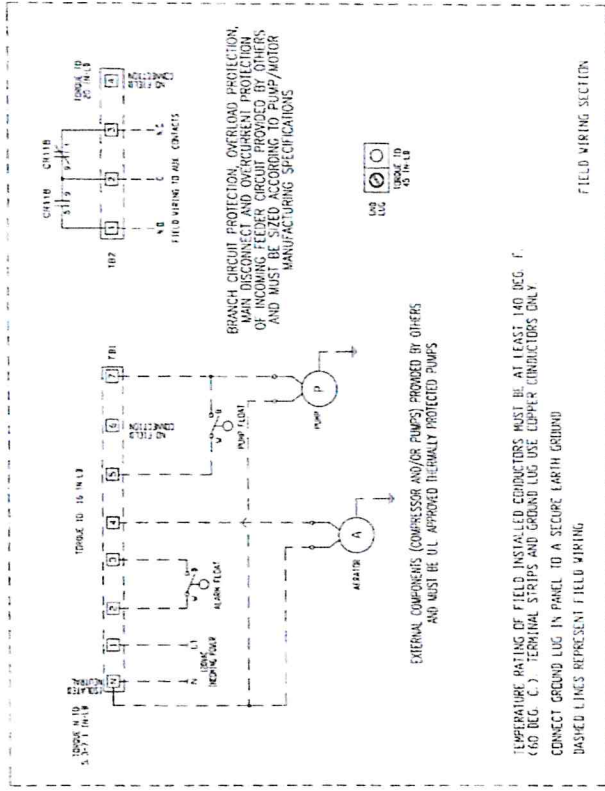
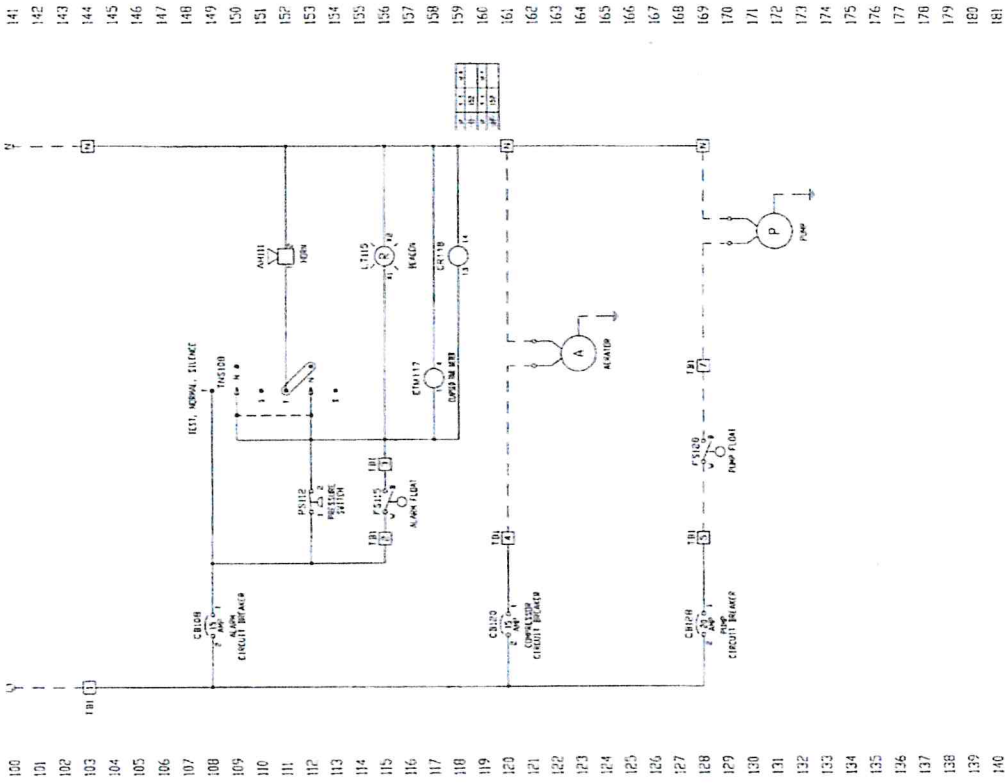

SIE RHOMBS									
REV	DATE	BY	CHKD	APP'D	DATE	BY	CHKD	APP'D	DATE
1	10/20/01	JLH	JLH	JLH	10/20/01	JLH	JLH	JLH	10/20/01
2	10/20/01	JLH	JLH	JLH	10/20/01	JLH	JLH	JLH	10/20/01
3	10/20/01	JLH	JLH	JLH	10/20/01	JLH	JLH	JLH	10/20/01
4	10/20/01	JLH	JLH	JLH	10/20/01	JLH	JLH	JLH	10/20/01
5	10/20/01	JLH	JLH	JLH	10/20/01	JLH	JLH	JLH	10/20/01
6	10/20/01	JLH	JLH	JLH	10/20/01	JLH	JLH	JLH	10/20/01
7	10/20/01	JLH	JLH	JLH	10/20/01	JLH	JLH	JLH	10/20/01
8	10/20/01	JLH	JLH	JLH	10/20/01	JLH	JLH	JLH	10/20/01
9	10/20/01	JLH	JLH	JLH	10/20/01	JLH	JLH	JLH	10/20/01
10	10/20/01	JLH	JLH	JLH	10/20/01	JLH	JLH	JLH	10/20/01

## Section 3d. System Components - Float Switch

The SJE Rhombus Signalmaster float switch may be pre-mounted in Fuji Clean USA treatment systems. In the event that the float switch needs to be installed or replaced, this information from SJE Rhombus is supplied for informed, proper handling during the installation process.

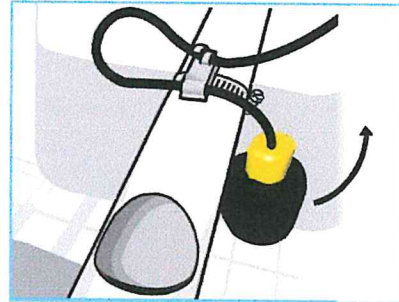
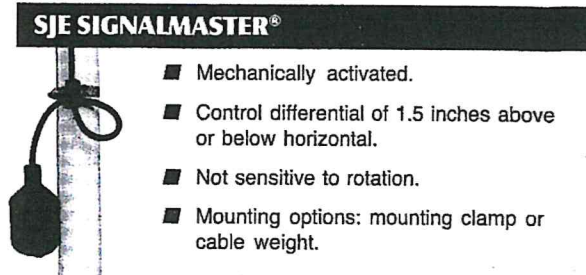

### Mounting the Switch

Install on the pumpback line using the provided hose clamp and mounting fixture in the center of Chamber 2, (Anaerobic Contact Filtration Chamber) with 3-1/2" (9 cm) of electrical cord tether.



**ELECTRICAL SHOCK HAZARD**  
Disconnect power before installing or servicing this product. A qualified service person must install and service this product according to applicable electrical and plumbing codes.



**EXPLOSION OR FIRE HAZARD**  
Do not use this product with flammable liquids. Do not install in hazardous locations as defined by National Electric Code, ANSI/NFPA 70.

Failure to follow these precautions could result in serious injury or death. Replace product immediately if switch becomes damaged or severed. Keep these instructions with warranty after installation. This product must be installed in accordance with National Electric Code, ANSI/NFPA 70 so as to prevent moisture from entering or accumulating with in boxes, conduit bodies, fittings, float housing, or cable.

#### PREVENTATIVE MAINTENANCE

- Periodically check the product. Check that the cable has not become worn or that the housing has not been damaged so as to impair the protection of the product. Replace the product immediately if any damage is found or suspected.
- Periodically check to see that the float is free to move and operate the switch.
- Use only SJE Rhombus replacement parts.
- The Sensor Float and Sensor Float Mini control switches contain mercury and MUST be recycle or disposed of according to local, state and federal codes.

## SJE-RHOMBUS® THREE-YEAR LIMITED WARRANTY

SJE-RHOMBUS® warrants to the original consumer that this product shall be free of manufacturing defects for three years after the date of consumer purchase. During that time period and subject to the conditions set forth below, SJE-RHOMBUS® will repair or replace, for the original consumer, any component which proves to be defective due to defective materials or workmanship of SJE-RHOMBUS®.

**THIS EXPRESS WARRANTY DOES NOT APPLY TO THE MOTOR START KIT COMPONENT. SJE-RHOMBUS® MAKES NO WARRANTIES OF ANY TYPE WITH RESPECT TO THE MOTOR START KIT.**

**ELECTRICAL WIRING AND SERVICING OF THIS PRODUCT MUST BE PERFORMED BY A LICENSED ELECTRICIAN.**

**THIS WARRANTY DOES NOT APPLY:** (A) to damage due to lightning or conditions beyond the control of SJE-RHOMBUS®; (B) to defects or malfunctions resulting from failure to properly install, operate or maintain the unit in accordance with printed instructions provided; (C) to failures resulting from abuse, misuse, accident, or negligence; (D) to units which are not installed in accordance with applicable local codes, ordinances, or accepted trade practices, and (E) to units repaired and/or modified without prior authorization from SJE-RHOMBUS®.

*Some states do not allow limitations on how long an implied warranty lasts, so the above limitation may not apply to you. Some states do not allow the exclusion or limitation of incidental or consequential damages, so the above limitation or exclusion may not apply to you. This warranty gives you specific legal rights, and you may also have other rights which vary from state to state.*

**TO OBTAIN WARRANTY SERVICE:** The consumer shall assume all responsibility and expense for removal, reinstallation, and freight. Any item to be repaired or replaced under this warranty must be returned to SJE-RHOMBUS®, or such place as designated by SJE-RHOMBUS®.

**ANY IMPLIED WARRANTIES OF MERCHANTABILITY OR FITNESS ARE LIMITED TO THE DURATION OF THIS WRITTEN WARRANTY. SJE-RHOMBUS® SHALL NOT, IN ANY MANNER, BE LIABLE FOR ANY INCIDENTAL OR CONSEQUENTIAL DAMAGES AS A RESULT OF A BREACH OF THIS WRITTEN WARRANTY OR ANY IMPLIED WARRANTY.**

# Section 3e. System Components – Wi-Fi Communications Device

The SJE Rhombus MySpy Wi-Fi Messenger requires controller communication contacts. Fuji Clean USA Controller “C” is the most basic controller model that provides these contacts. This device must be mounted within range of home Wi-Fi signal.

## MySpy® WiFi Messenger Alarm System

Easy-to-install indoor alarm system with WiFi connectivity, remote notification, battery backup, and auto reset.

The MySpy® WiFi Messenger system monitors and reports any residential alarm condition (contact closure), including sump high water level (float switch), or under/over temperature alarms. When the contact closes, the alarm notifies the user locally (audible and visual alarm) and remotely via SMS text messages and/or emails over a WiFi or Ethernet network to a smartphone, tablet or computer. The horn can be silenced when the alarm is active, but the alarm light remains on until the condition is cleared. Once the condition is cleared, the alarm will automatically reset.

No cellular connection needed (no monthly fees), but it is necessary for the home owner to have a reliable WiFi network and connection to the internet for this alarm to send remote notifications. Text message notifications can be sent to a cell phone with an active SMS service.



### FEATURES

- NEMA 1 enclosure rated for indoor use.
- Automatic alarm reset.
- Red “alarm” light, green “power on” light, blue “network status” light, alarm “test” switch, horn “silence” switch, and WiFi Protected Setup (WPS) connection button.
- WiFi connectivity for remote alarm reporting
  - WiFi Protected Setup (WPS) push-button connect feature for simplified connection.
  - Manual WiFi setup done through Ethernet connection.
- Ethernet connectivity for remote alarm reporting - for cabled connection to router or modem (cable not included).
- Notifies the user via text and/or email notifications of the following conditions: Alarm, Power Lost, Power Restored, Low Battery, and Alarm Offline.
 

**NOTE: Installation of an Uninterruptible Power Supply (UPS) on internet modem and wireless router is recommended. The internet connection must be maintained to receive notifications.**
- Notifies up to 4 contacts (2 text and 2 email contacts).
- Alarm horn sounds at 87 decibels at 10 feet (3 meters).
- Can be used with any switching mechanism rated to include 1 amp, 9 VDC load.
- If primary power fails, the alarm system continues to work locally due to battery backup feature. (battery not included.)
 

**NOTE: A Power Lost notification will be sent when entering battery backup mode, but other email and text notifications will not be sent in this mode.**
- Complete package includes standard SJE SignalMaster® control switch with 15 feet (4.57 meters) of cable and mounting clamp.
- Switching mechanism operates on low voltage and is isolated from the power line to reduce the possibility of shock.
- Auxiliary alarm contacts for easy attachment of remote devices
- Low battery chirp.
- Easy access battery compartment.
- External terminal block for easy float switch installation.
- CSA Certified.
- Five-year limited warranty.



### OPTIONS

- When ordered with the alarm, this system is available with:
- Alternate float switch models for high or low level warning.
  - Splice kit.

SEE BACKSIDE FOR ORDERING INFORMATION.  
SEE PRICE BOOK FOR LIST PRICE.

### SPECIFICATIONS

- VOLTAGE FOR 120 VAC MODEL:**  
 Primary: 120 VAC, 60 Hz, 2.4 watts max. (alarm condition)  
 Secondary: 9 VDC
- BATTERY BACKUP POWER:** 9 VDC
- ALARM ENCLOSURE:** 6 x 4 x 2.25 inch (15.24 x 10.16 x 5.71 cm), NEMA 1 plastic.
- ALARM HORN:** 87 decibels at 10 feet (3 meters)
- AUXILIARY ALARM CONTACTS**  
 Voltage: 120 VAC  
 Current: 0.5 amps maximum N/O  
 0.5 amps maximum N/C
- POWER CORD:** 6 foot (1.8 meter)
- FLOAT SWITCH CONNECTION TERMINAL:**  
 For float switch connection only. Do not apply power. (Voltage across terminals is 8-9 VDC).
- FLOAT SWITCH:** SJE SignalMaster® control switch with mounting clamp  
 Cable: 15 feet (4.57 meters), flexible 18 gauge, 2 conductor (UL) SJOW, water-resistant (CPE)  
 Float: 2.74 inch diameter x 4.83 inch long (7.0 cm x 12.3 cm), high impact, corrosion resistant polypropylene housing for use in sewage and water up to 140°F (60°C)
- WiFi:** Connect using push-button WiFi Protected Setup (WPS) or manually by using Ethernet connection (ethernet cable not provided). WPA2 security required on wireless router.
- ETHERNET:** Requires an ethernet connection (ethernet cable not provided).
- NOTE:** Cellular WiFi hotspots are not recommended for use with this WiFi alarm, as intermittent or unreliable notification service can result.



## SJE RHOMBUS

PO Box 1708, Detroit Lakes, MN 56502  
 1-888-DIAL-SJE • 1-218-847-1317  
 1-218-847-4617 Fax  
 email: customer.service@sjerhombus.com  
[www.sjerhombus.com](http://www.sjerhombus.com) D.1

# MySpy® WiFi Messenger Alarm System

Easy-to-install liquid level alarm system with WiFi connectivity, remote notification, auto-reset, and battery backup features for indoor use.

## ORDERING INFORMATION

120 VAC		Shipping Weight
Part #	Description	
1043586	MSWF-01H (120 VAC w/15' SJE SignalMaster® High Level)	2.73 lbs.
1043655	MSWF-01L (120 VAC w/15' SJE SignalMaster® Low Level)	2.73 lbs.
1043656	MSWF-01H (120 VAC w/15' Sensor Float® High Level)	2.81 lbs.
1043657	MSWF-01X (120 VAC no float)	1.44 lbs.

H = High Level L = Low Level X = No Float

MASTER CARTON holds 16 boxed units.  
SEE PRICE BOOK FOR LIST PRICE.

## OPTIONS

### CONTROL SWITCH OPTIONS

The MySpy® WiFi Messenger alarm system comes standard with a 15ft SJE SignalMaster® control switch with mounting clamp. Other float switches are available. See control switch section of the catalog.

To determine the price of alarm with an alternate float, add the price of the part number with "no float" to the price of the float switch.

## SPECIFICATIONS

### VOLTAGE FOR 120 VAC MODEL:

Primary: 120 VAC, 50/60 Hz, 2.4 watts max. (alarm condition)  
Secondary: 9 VDC

### BATTERY BACKUP POWER: 9 VDC

**ALARM ENCLOSURE:** 6 x 4 x 2.25 inches (15.24 x 10.16 x 5.71 cm),  
NEMA 1 plastic

**ALARM HORN:** 87 decibels at 10 feet (3 meters)

**AUXILIARY ALARM CONTACTS:** 120 VAC, 0.5 amps max N/O,  
0.5 amp max N/C

**POWER CORD:** 6 foot (1.8 meter)

**FLOAT SWITCH CONNECTION TERMINAL:** for float switch connection only  
(voltage across terminals is 8-9 VDC)

**FLOAT SWITCH:** SJE SignalMaster® control switch with mounting clamp

**CABLE:** 15 feet (4.57 meters), flexible 18 gauge, 2 conductor (UL)  
SJOW, water resistant (CPE)

**FLOAT:** 2.74 inch diameter x 4.83 inch long (7.0 cm x 12.3 cm), high impact, corrosion resistant polypropylene housing for use in sewage and water up to 140°F (60°C)

**WIFI:** Connect using push-button WIFI Protected Setup (WPS) or manually by using Ethernet connection (ethernet cable not provided).

**ETHERNET:** Requires an ethernet connection (ethernet cable not provided). WPA2 security required on wireless router.

**NOTE:** Cellular WiFi hotspots are not recommended for use with this WiFi alarm, as intermittent or unreliable notification service can result.



**SJE RHOMBUS**

www.sjerhombus.com  
customer.service@sjerhombus.com

**Call or fax your order!**

1-888-DIAL-SJE (1-888-342-5753) / Fax 218-847-4617

Product offering and pricing are subject to change without notice.  
Please visit [www.sjerhombus.com](http://www.sjerhombus.com) for the most current information.

9500126C  
© SJE-Rhombus 12.17

## Section 4. Maintenance Program

### **Scheduled Maintenance – General**

If sampling is required, please draw samples prior to maintenance protocol. Refer to Appendix 3 for proper sampling procedure.

Regularly scheduled maintenance by a qualified service professional is necessary for efficient operation of this system. The recommended frequency of scheduled maintenance is semi-annually and will typically take a service professional about 20 minutes to complete per visit. Proper maintenance also requires sludge be pumped out from the system on a periodic basis. The frequency of pump-out depends on the system's loading but is recommended approximately once every two years, and more frequently for systems that treat heavy flows and loads.

Consumable parts for the blower such as the blower diaphragms and air filter should be replaced regularly. The recommended replacement interval for these parts is 12 months, although site conditions (such as air quality) may warrant a longer or shorter interval.

---

### **Regular Maintenance Procedures**

- 1. Outside Environment Check. (Recommended frequency: start-up and 1x every 6 months)**
  - The system is accessible and nothing inhibits access to maintenance.
  - Surface water is draining away from risers and covers.
  - No signs of physical damage to the treatment system, piping, alarms or components
  - No unusual smells around the system.
  - No unusually loud blower noise, such as rattling.
  
- 2. Blower Box Check. (Recommended frequency: Start-up and 1x every 6 months)**

Open the blower box, make sure that it is operating properly.  
Inspect all fittings and vents to ensure they are clean and dry.
  
- 3. Blower Operation and Blower Alarm Check. (Recommended frequency: Start-up and 1x every 6 months)**

Make sure the blower operates properly. Clean the air filter or replace it, if necessary. Turn off the blower for few moments to check that the alarm is triggered.
  
- 4. Blower Consumable Components (Recommended frequency: air filter inspection 1x every 6 months. Diaphragm replacement as required.)**

The blower contains an air filter and diaphragms, which are considered “consumables.” The air filter should be inspected and cleaned/replaced regularly. Diaphragms and their casings should be replaced regularly to maximize blower life and efficiency. The recommended frequency for each of these procedures is once annually. Please follow steps on the following page.

## Blower Air Filter Cleaning / Replacement Procedure

Replacing the blower air filter is very simple and consists of removing the filter cover with a Phillips screwdriver, removing the old, cleaning it (blow clean with air pressure) or replacing it with a new filter, and then screwing the cover back into place.

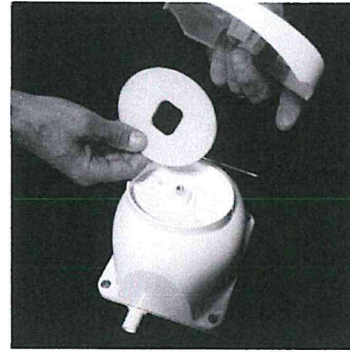
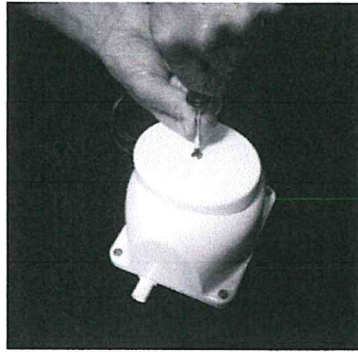

## Blower Diaphragm Replacement Procedure

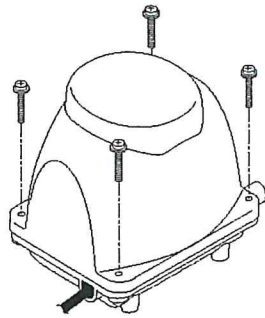

**Step 1.** Remove cover bolts and screw with 8mm socket and screwdriver

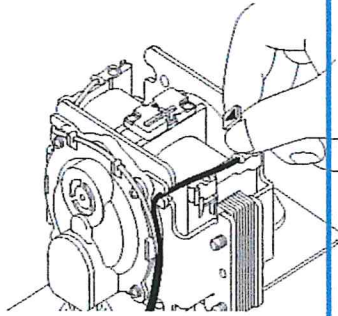

**Step 2.** Remove autopiece stop as shown:

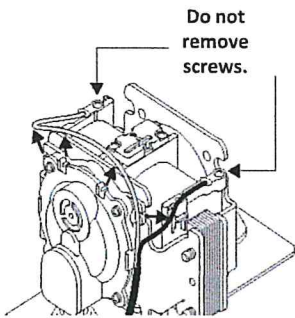
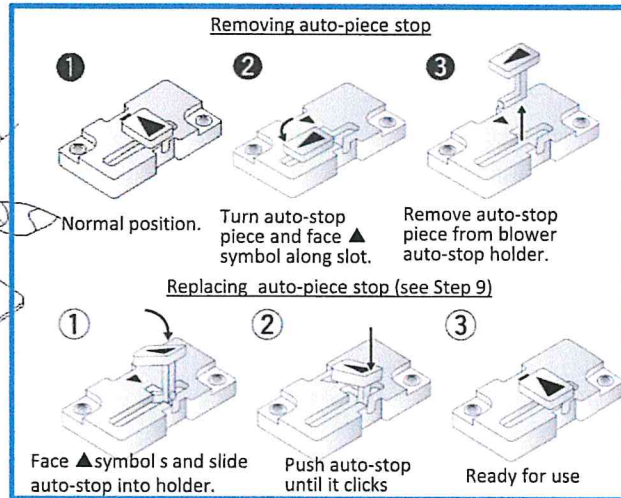

**Step 3.** Remove power cable from 4 hooks. Do not remove screws.

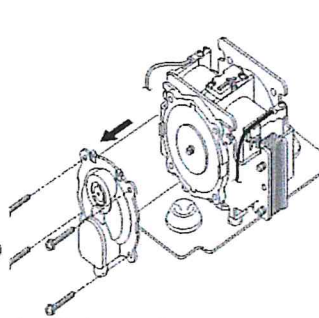

**Step 4.** Remove 4 screws from one casing.

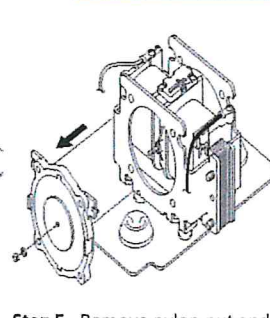

**Step 5.** Remove nylon nut and diaphragm from body

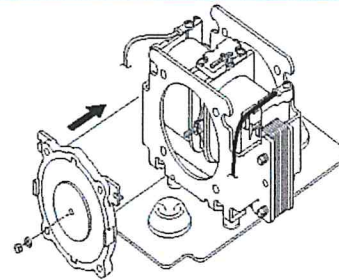

**Step 6.** Install new diaphragm using new nylon nut provided. Torque tighten to about 1 Nm.

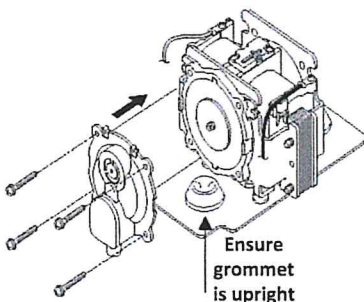

**Step 7.** Insert casing air outlet into rubber grommet. Secure with 4 screws. Repeat Steps 4-7 for 2<sup>nd</sup> diaphragm.

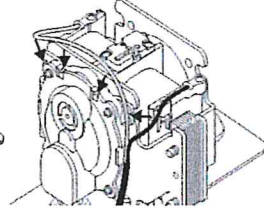

**Step 8.** Fit power cable onto 4 hooks.

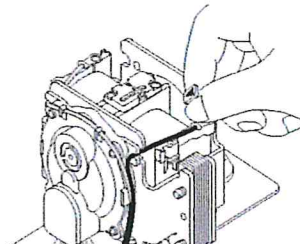

**Step 9.** Re-set auto-piece stop as shown above

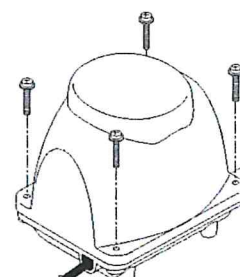

**Step 10.** Replace cover bolts and screw.



Open all access covers and secure the area around the access openings.

**5. Treated Effluent Check. (Recommended frequency: 1x every 6 months)**

Collect a sample of treated effluent from the aeration chamber and evaluate for clarity and odor and pH. Sample should be nearly clear and with a faint musty smell. If sample is cloudy or exhibits a septic odor, then the system is not treating properly and requires maintenance. Please refer to the Troubleshooting Guide for direction. pH should be checked. If too low, procedures should be implemented to correct. (see Troubleshooting Guide).

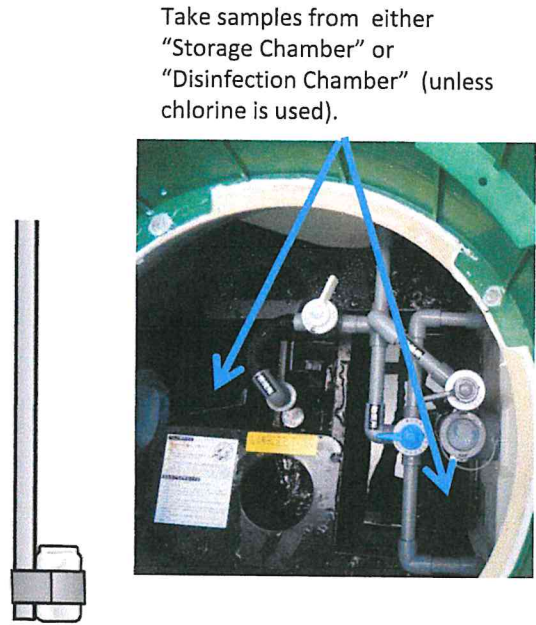

Take samples from either "Storage Chamber" or "Disinfection Chamber" (unless chlorine is used).

**6. High Water Float Switch Check. (Recommended frequency: Start-up and 1x every 6 months)**

Check that the high water float switch is operating freely. Lift up the high water float switch to check that the alarm is triggered. (Note: Float's activation horizon is 1.5" above or below level horizon).

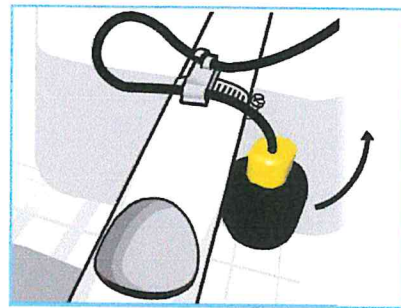

**7. Inflow Pipe Check. (Recommended frequency: Start-up and 1x every 6 months)**

Make sure that the inflow pipe is not blocked.



**8. Transfer Scum. (Recommended frequency: 1x every 6 months)**

If any scum appears in the Chamber 3, scoop with a ladle or a collection jar and transfer it into the sedimentation chamber.

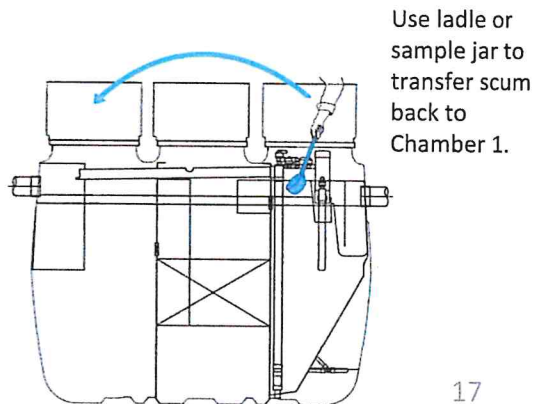

Use ladle or sample jar to transfer scum back to Chamber 1.

**9. Set Recirculation Control Valve. (gray)  
(Recommended frequency: Start-up and 1x every 6 months)**

The recirculation valve (gray) should be set to its default setting range according to the table below for ALL flows.

Model	Default Setting (%)
CE5	30% to 35%
CE7	25% to 30%
CE10	25% to 30%
CEN5	35% to 40%
CEN7	25% to 35%
CEN10	25% to 35%

At start-up, and for standard operation, the Recirculation Control Valve (gray) should be set according to the table and instructions listed under Procedure #9. NOTE: CEN systems have a higher recirculation rate than CE systems.



CE Systems



CEN Systems

(Within the ranges shown in the table above, set at lower end for projected below average hydraulic flows and at the higher end for higher average projected hydraulic flows.)

Important! Normal recirculation flow should be level with the top edge of the airlift pumpback line cut-out spilling into Chamber 1. If backflow is too high or too low, this typically indicates that service cleaning is required (O&M Steps 12-16).



**10. Check/Set Aeration Balance Control Valve (blue).  
(Recommended frequency: Start-up and 1x every 6 months).**

The default, normal setting for the Aeration Control Valve is 50%. Visually observe the airflow rates on each side of the plant by checking to see if bubbles are evenly distributed on both sides of the aeration chamber. If there is an obvious discrepancy in airflow between the two sides, adjust the Aeration Balance Control Valve so that the airflow is equal. Important! If adjustment of this valve is ineffective, then the likely cause of uneven bubbles is usually a blockage in the aeration pipes and is corrected with aeration pipe cleaning: See O&M Step # 14.



At start-up, and for standard operation, the Aeration Balance Control Valve (blue) should be set to 50%.

**11. Check/Set Effluent Airlift Valve (white). (Recommended frequency: Start-up and 1x every 6 months)**

The Effluent Control Valve is initially set to 40% and there is typically no need for it to be adjusted under standard conditions.



At start-up, and for standard operation, the Effluent Airlift Valve (white) should be set to 40%. 18

**12. Backwash and Sludge Transfer. (Recommended frequency: 1x every 6 months)**  
Perform a backwash and sludge transfer operation.

Excessive biofilm growth on the contact and filter media (Chambers 2 and 3) may cause partial clogging or short circuiting and deteriorate the performance of the system. It is essential to carry out this backwash operation and sludge transfer at every maintenance visit.

**A.** Shut off the Effluent Air-lift Pump by turning the Effluent Control Valve (white valve) clockwise until it won't turn any more.

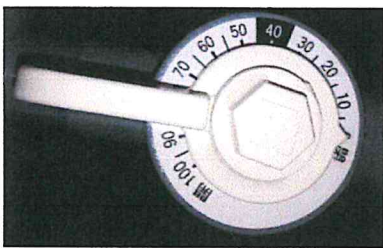

**B.** Transfer the sludge on the bottom of the aeration chamber by turning the Recirculation Control Valve (grey valve) to 70-80 and wait for one minute.

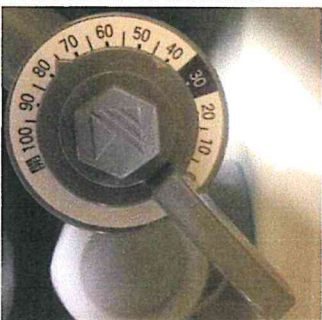

**C.** Reset the Recirculation Control Valve (grey valve) to the original position.



CE Systems



CEN Systems

**D.** Aerate one side of the chamber by turning the Aeration Balance Control Valve (blue valve) fully one way. Wait for one minute, and then turn the valve fully to the opposite direction. Wait for another minute, and then reset the valve to the original position



**E.** Repeat Steps B-D three times.

**F.** Final repeat of Step B.

**G.** Flush the Effluent Control Valve (white) by rotating the valve back and forth from 0 to 100 several times.



**H.** Reset the Recirculation Control Valve (grey valve) and the Effluent Control Valve (white valve) to their original positions. Make sure that the aeration is working properly.



**I.** Poke and penetrate into the anaerobic filtration media with a small diameter PVC pipe (e.g. ½-inch) gently and evenly throughout Anaerobic Filtration Chamber for media degassing. This is a simple but essential procedure to assure uniform media contact and filtration.

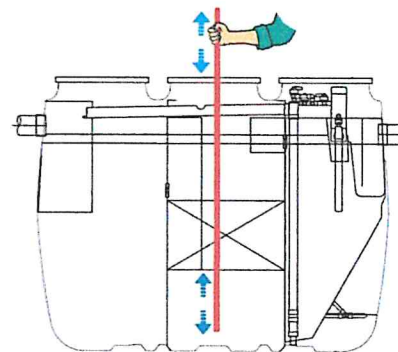

**13. Check / Clean Effluent Airlift Pipe. (Recommended frequency: Start-up and 1x every 6 months)**  
Check the observation port in the airlift line to see if there is smooth water flow from the effluent airlift pump. If there is uneven flow or a disruption in flow, then clean the airlift pipe with a cleaning brush.



**14. Clean Recirculation Air-lift Pump (Recommended frequency: 1x every 6 months)**  
Excessive biofilm build-up in the recirculation air-lift pump may affect the recirculation rate. Remove the plastic cap on the air-lift head, clean inside the pipe with a pipe cleaning brush. Also clean the recirculation pumpback line as shown.

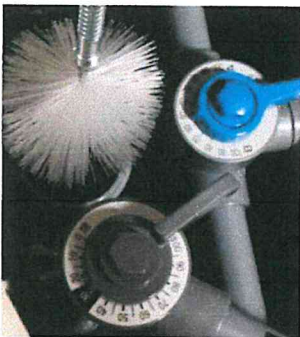

**15. Refill the chlorinator (if applicable).** Place refill chlorination tablets in the chlorinator tube and adjust the dissolve rate by rotating the bottom cap of the chlorinator.



**16. Cleaning Aeration Pipes (Recommended frequency: 1x every 6 months or as required)**  
Aeration Pipes should be cleaned if bubbles are unevenly distributed even after adjusting the aeration balance or the recirculation flow rate has increased considerably without resetting Recirculation Valve (gray valve).

Use hose adaptor supplied by Fuji Clean USA.

**A.** Close the Recirculation Control Valve (grey valve) and the Effluent Control Valve (white valve).

**B.** Turn off the blower.

**C.** Disconnect a barrel union. HINT: Just unscrew union and pull off air line. Do not totally disconnect barrel union.

**Clean With Hose:** (Use for standard cleaning)  
Attach adaptor with check valve (provided by manufacturer) to garden hose and connect with aeration pipe. Run water from spigot for 1 minute. Repeat for the 2<sup>nd</sup> aeration pipe.

**D.** Reconnect aeration pipes, turn on blower and re-set standard valve settings (see O&M Procedure #'s 10-12)

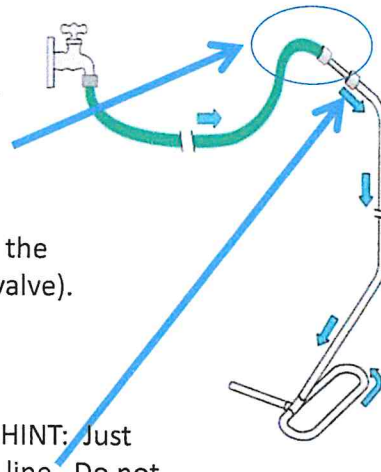

**17. Measure Sludge and Pump Out if Necessary**  
**(Recommended frequency: 1x every 2 years or as required)**

- Biological treatment performance is severely deteriorated due to excessive amounts of oil or chemicals which interfere with the bacterial activity.
- For residential models, when sludge levels reach more than 35-inches in Chamber 1 or more than 16-inches in Chamber 2.
- Abnormal rise of the water level
- Excessive scum builds up in Chamber 2, the Anaerobic Filtration Chamber and large amounts of solids flow into Chamber 3, the Aerobic Filtration Chamber, even after performing a sludge transfer operation (O&M procedure #12).

**PUMP-OUT INSTRUCTIONS**

**Step 1.** Turn off all electrical components.

**Step 2.** Clean the inlet and outlet pipe.

**Step 3.** Transfer suspended solids and scum from Chamber 3 back to Chamber 1.

**Step 4.** With pumpout hose, remove scum and sludge on the filtration media from Chamber 2 **FIRST!** Otherwise you risk solids being drawn up into the media in Chamber 2.

**Step 5.** Insert suction hose into the baffle. Remove sludge from the bottom Chamber 2. Wash media and chamber wall.

**Step 6.** Remove scum and sludge Chamber 1.

**Step 7.** Re-fill the system with water to Low Water Level (LWL).

**Step 8.** Turn on all electrical components.

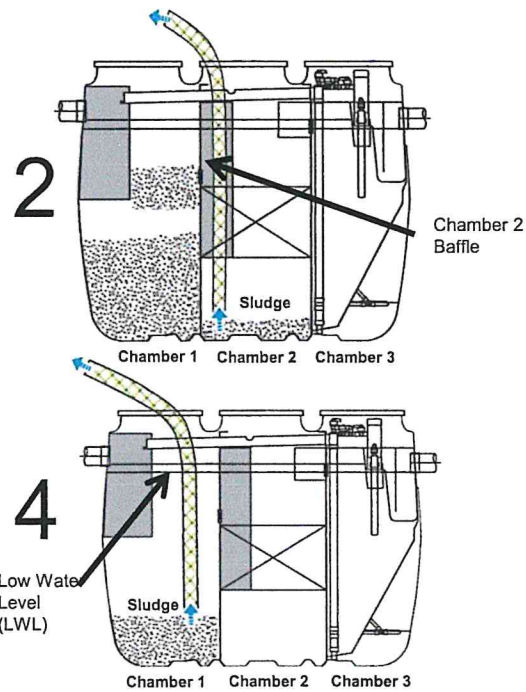
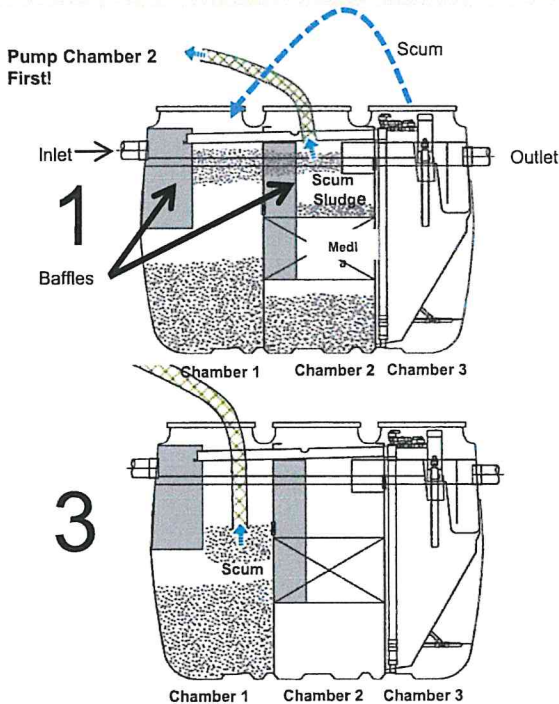

**18. Measure and Record Dissolved Nitrogen with testing strips in applicable sites.**  
**(Recommended frequency: 1x every 6 months or as required).**



**SYSTEM INSPECTION CHECKLIST REPORT – Fuji Clean CE and CEN Systems**

To be completed by authorized service provider at each inspection/service visit – 2x per year. Please follow the O&M Maintenance Program in the Fuji Clean O&M Manual. Please contact Fuji Clean USA with questions, comments and/or troubleshooting assistance. The Authorized Service Provider must maintain a copy of this report in records.

**SYSTEM SITE**

Name: \_\_\_\_\_

Address: \_\_\_\_\_

\_\_\_\_\_

Town/State: \_\_\_\_\_

Contact: \_\_\_\_\_

Contact Info: \_\_\_\_\_

**AUTHORIZED SERVICE PROVIDER**

Service Date: \_\_\_\_\_

Name: \_\_\_\_\_

Company: \_\_\_\_\_

Town/State: \_\_\_\_\_

License No. (if applicable): \_\_\_\_\_

Contact Info: \_\_\_\_\_

<b>SERVICE PROCEDURE / OPERATION</b>	<b>COMMENT / DATA/OBSERVATION (use reverse if nec.)</b>
<input type="checkbox"/> 1. Outside Environment Check	_____
<input type="checkbox"/> 2. Blower Box Check	_____
<input type="checkbox"/> 3. Blower Operation and Blower Alarm Check	_____
<input type="checkbox"/> 4. Replace blower Consumable Components if nec.	_____
<input type="checkbox"/> 5. Treated Effluent Check Clarity (Required)	_____
Odor (Required)	_____
pH (Required)	_____
DO (Recommended)	_____
<input type="checkbox"/> 6. High Water Float Switch Check	_____
<input type="checkbox"/> 7. Inflow Pipe Check	_____
<input type="checkbox"/> 8. Transfer Scum to Sedimentation Chamber	_____
<input type="checkbox"/> 9. Check/Set Recirculation Control Valve	_____
<input type="checkbox"/> 10. Check/Set Aeration Balance Control Valve	_____
<input type="checkbox"/> 11. Check/Set Effluent Airlift Valve	_____
<input type="checkbox"/> 12. Backwash and Sludge Transfer ( <b>Important!</b> )	_____
<input type="checkbox"/> 13. Check/Clean Effluent Airlift Pipe	_____
<input type="checkbox"/> 14. Check/Clean Recirculation Airlift Pipe	_____
<input type="checkbox"/> 15. Refill Chlorinator (if applicable)	_____
<input type="checkbox"/> 16. Clean Aeration Pipes (if necessary)	_____
<input type="checkbox"/> 17. Measure Sludge and Pump out if necessary*	_____
Sedimentation Chamber (Chamber 1)	_____
Anaerobic Chamber (Chamber 2)	_____
<input type="checkbox"/> 18. Measure & Record Dissolved N (if Applicable)	_____
<input type="checkbox"/> 19. Check Flow Monitor Component (NJ only)	_____

\* Pump out reminder. If 35" or more of sludge accumulates in the Sedimentation Chamber (1<sup>st</sup> chamber), or 16" or more in the Anaerobic Chamber (2<sup>nd</sup> chamber), the system should be pumped. Pump 2<sup>nd</sup> chamber first followed by the 1<sup>st</sup> chamber. Please refer to the Fuji Clean USA O&M Manual for detail.

# TROUBLESHOOTING

## General

SYMPTOM	SOLUTION
Water is ponding around risers and covers	Landscaping is necessary (possibly involving addition of fill material) so that water drains away from risers and covers. Note: risers may be added to the unit as necessary, but service personnel must be able to reach into the unit and move controls. Recommended maximum riser height is 24-inches.
Strong and unusual odor exists even with the manhole lids closed.	<p>During the first few weeks of operation there may be noticeable odor from the system. This should cease once the bacteria are established.</p> <p>If odor persists, seeding material may be added to both anaerobic and aeration chambers, and/or the recirculation rate may be increased to 35%, the upper end of the normal operation range.</p> <p>If odor continues to persist, please contact manufacturer for instructions. Installation of a vent may be necessary.</p>
Blower is making an unusually loud noise	Normal blower operation is quiet. Typically a loud or rattling blower noise is created when the blower is in contact with its housing, or has slipped off its base platform.

# TROUBLESHOOTING

## Chamber 1. Sedimentation Chamber

SYMPTOM	SOLUTION
Inlet pipe is blocked	Remove the blockage.
Excessive scum accumulations. (Scum layer reaches the top of the influent baffle)	Measure sludge level. If the depth of sludge accumulation is less than 24-inches (or 18-inches in Chamber 2), break the scum layer, otherwise have the plant pumped out.
Excessive sludge accumulations. (Depth of sludge layer exceeds 24-inches)	If the sludge exceeds the holding capacity, have the plant pumped out.
Foreign materials, excessive oil or fat entering the system.	Remind the homeowner to refrain from disposing harmful substances into their system. (Please refer to Homeowner's Manual for listing.)



## TROUBLESHOOTING

### Chamber 2. Anaerobic Filtration Chamber

SYMPTOM	SOLUTION
Excessive scum accumulation. (less than 4-inches)	If Chamber 1, the Sedimentation Chamber still has the remaining sludge holding capacity, (less than 24-inches of sludge build-up), transfer the scum to the sedimentation chamber, otherwise have the plant pumped out.
Excessive scum accumulation. (more than 4-inches)	Have the plant pumped out.
Excessive sludge accumulations	If the bottom sludge layer is thicker than 18-inches and excessive sludge has accumulated on the filtration media, have the plant pumped out.
Filtration media is blocked up. (The water level in Chamber 2's media is lower than that in the baffle.)	<p>Perform a degassing operation on the filtration media. (Poke media with a section of PVC pipe. See O&amp;M procedure #12).</p> <p>If the problem still persists even after the degassing and sludge transfer operation, pressure wash the filtration media using an effluent pump and hose affixed to a PVC pipe.</p>
Foreign materials, excessive oil or fat entering the system.	Remind the homeowner to refrain from disposing prohibited substances and limited-use substances.

# TROUBLESHOOTING

## Chamber 3. Aerobic Contact Filtration Chamber

SYMPTOM	SOLUTION
Bubbles are not evenly distributed throughout the chamber or there are no bubbles at all.	<ul style="list-style-type: none"> <li>• Adjust the aeration control valve.</li> <li>• Check to make sure that there is no leakage from the aeration pipework.</li> <li>• Check to make sure that the blower operates properly.</li> <li>• Clean the aeration pipes</li> <li>• Perform a backwash operation. (O&amp;M Procedure #12).</li> </ul>
Dissolved Oxygen is less than 1.0mg/L.	<ul style="list-style-type: none"> <li>• Check to make sure that the blower operates properly.</li> <li>• Perform a backwash operation. (O&amp;M Procedure #12).</li> </ul>
Recirculation rate is unable to be adjusted or no recirculation at all.	<ul style="list-style-type: none"> <li>• Adjust the recirculation control valve.</li> <li>• Check to make sure that there is no leakage from the aeration pipework.</li> <li>• Check to make sure that the blower operates properly.</li> </ul>
Recirculation flow rate is too high	<ul style="list-style-type: none"> <li>• Clean the aeration pipes</li> </ul>
Recirculation flow rate is too low	<ul style="list-style-type: none"> <li>• Clean the recirculation airlift pump.</li> </ul>
Excessive foaming.	<ul style="list-style-type: none"> <li>• Some foaming may occur during the early stage of operation. This should cease once the bacteria are established. Seeding may also be effective. Please contact your distributor for additional seeding information.</li> </ul>
Excessive suspended solids.	<ul style="list-style-type: none"> <li>• Perform a backwash operation.</li> </ul>
Cold water is hampering treatment	<p>The following measures will allow greater oxygen penetration into biofilm.</p> <ul style="list-style-type: none"> <li>• Increase frequency of backwash</li> <li>• Increase blower size</li> <li>• Perform desludge operation (i.e. sludge pumpout)</li> </ul>

# TROUBLESHOOTING

## Chamber 3a. Storage Chamber

SYMPTOM	SOLUTION
Scum forming.	<ul style="list-style-type: none"><li>• Transfer the scum to Chamber 1, the Sedimentation Chamber, using a pump, ladle or suitable container.</li><li>• Increase the recirculation rate (within the normal operating range).</li></ul>
Excessive sludge accumulations.	<ul style="list-style-type: none"><li>• Transfer the sludge to Chamber 1, the Sedimentation Chamber, using a pump, ladle or suitable container.</li></ul>
Ph is too low or too high. (Ph < 5.8 or Ph > 8.6)	<ul style="list-style-type: none"><li>• Check to make sure the recirculation rate is appropriate.</li><li>• Remind homeowner of what cannot be put into this system (refer to Homeowner's Manual).</li><li>• Install a slow-release lime dispersal system into the sedimentation chamber to raise the pH. Please contact Fuji Clean USA for details.</li></ul>
Excessive biofilm on the chamber wall.	<ul style="list-style-type: none"><li>• Clean the wall with brush or water pressure and transfer solids to the sedimentation chamber.</li></ul>
Effluent airlift pump is not working.	<ul style="list-style-type: none"><li>• Clean the airlift pump.</li><li>• Flush the effluent control valve.</li><li>• Check to make sure there is no leakage from the blower pipework.</li><li>• Check to make sure that the blower operates properly.</li></ul>

# TROUBLESHOOTING

## Air Blower

What to observe

Status

How to solve the problem

**Blower is not working**

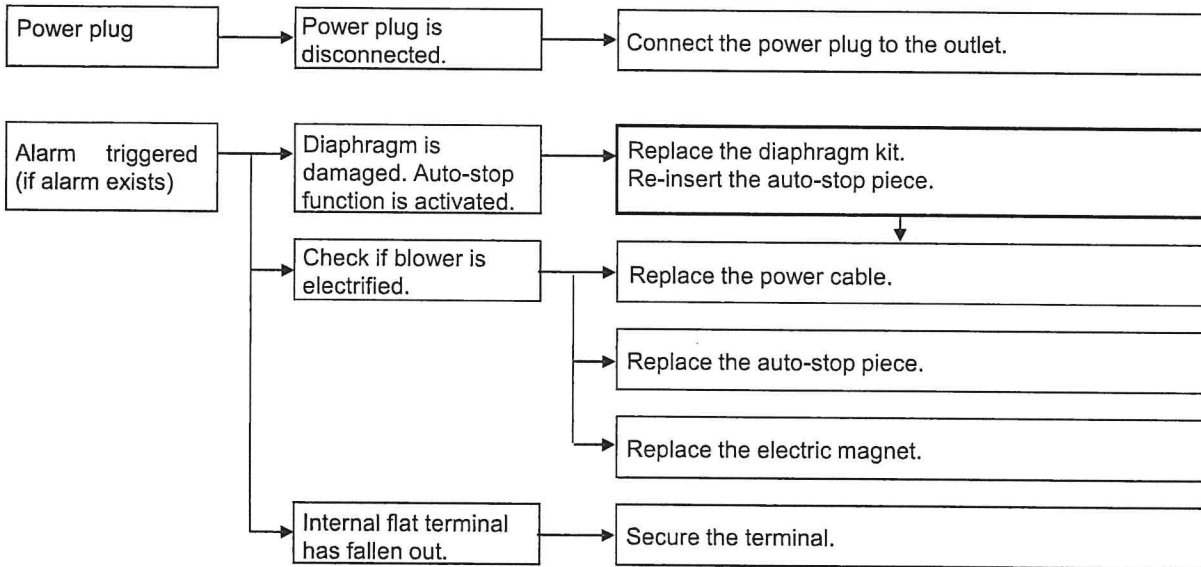

**Blower is making an abnormal or excessive operating noise.**

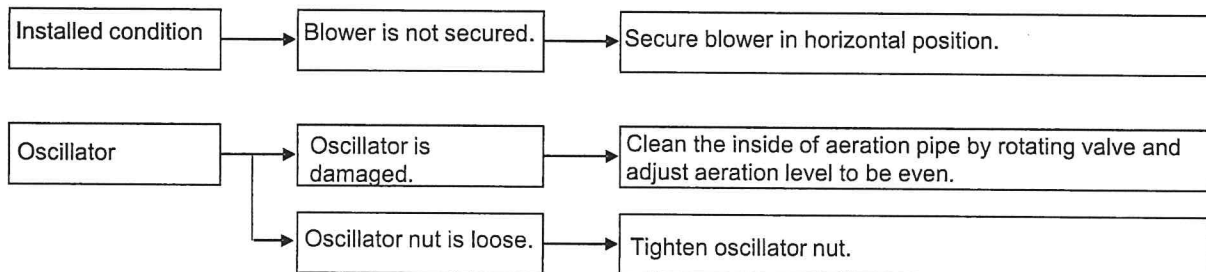

**Low air volume or misplaced air from aeration pipes (treatment plant)**

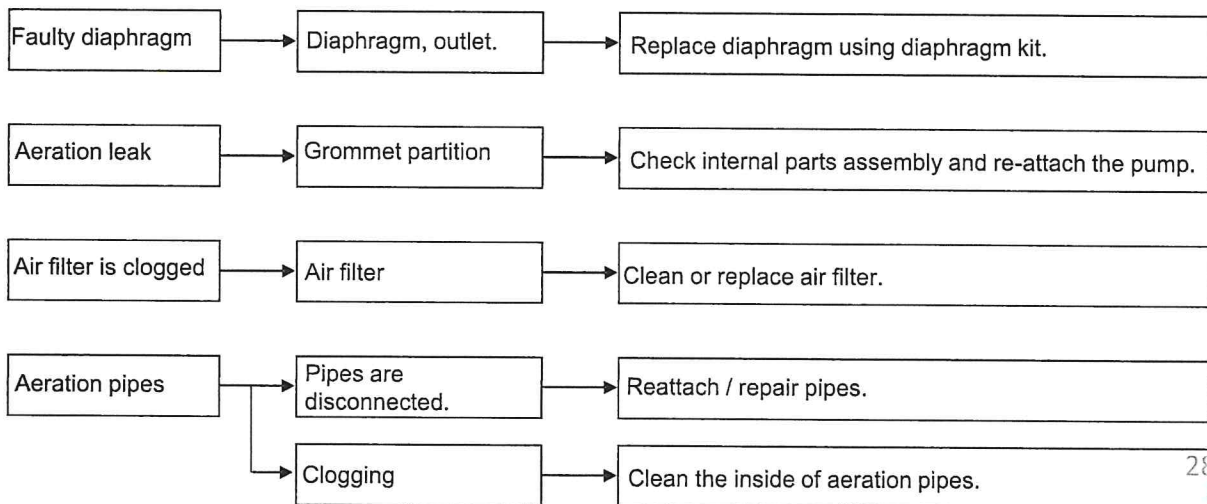



## Owner's Manual – Residential Systems

Rev. 7-17-2019

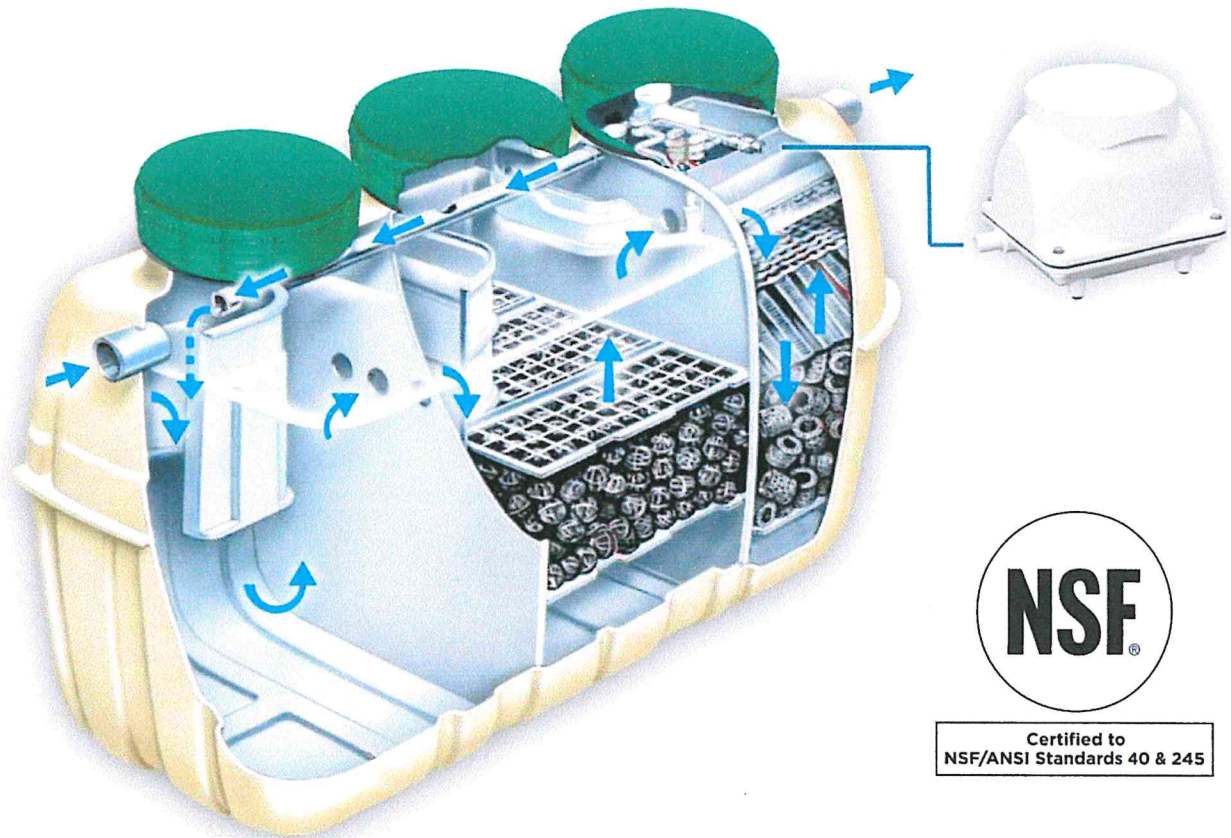

### Intelligently Engineered Treatment Systems for Domestic Wastewater

**Service Provider:**

**Name:** \_\_\_\_\_

**Company:** \_\_\_\_\_

**Address:** \_\_\_\_\_

**Telephone:** \_\_\_\_\_

**Email:** \_\_\_\_\_

**Model:**

CE5       CE7       CE10

CEN5       CEN7       CEN10

CE models are certified to NSF/ANSI 40 Standards

CEN models are certified to NSF/ANSI 40/245 Standards

**System Serial #** \_\_\_\_\_

**Blower Serial #** \_\_\_\_\_

## **Thank You!**

Thank you for choosing a Fuji Clean USA treatment system. You have selected a technology from the world's #1 onsite treatment manufacturing company with over 2 million treatment systems installed and operating world-wide. We want you to understand your treatment system and how to treat it wisely. We also understand that you just want it to work. No drama! Your Fuji Clean system investment will not only assure the long-term health of your drainfield, but will also enhance the ecological health of your outside home environment.

## **What it Does**

Your Fuji Clean treatment system is essentially your own personal wastewater treatment plant. Dirty "domestic" (i.e. household, from bathrooms, kitchen, sinks etc.) wastewater goes in and clean water comes out, which then flows into the environment, such as into a leachfield. Designed to produce a consistent, high-quality treated effluent, your Fuji Clean treatment system is a living biological ecosystem that relies on billions of living microbes to consume the pollutants in wastewater. Oxygen is introduced to keep the microbes alive and healthy (hence the air blower) and various forms of high surface area plastic "media" are incorporated into the system to provide space for microbes to live and consume waste material.

## **Why do I Have this System?**

Not every onsite septic system requires treated effluent. The designer of your system likely specified treatment because site conditions (such as lot size, soil conditions, proximity to an environmentally sensitive area or effluent requirements) demanded treatment. Your Fuji Clean treatment system is simply an appliance to assure the long term health of wastewater disposal on your home site. It works for you. Thank you for treating it with respect and care.

## **The Fuji Clean Story**

The lack of available land in Japan for on-site wastewater disposal has driven Japanese on-site wastewater treatment technology way ahead of the standard we typically experience in America. In Japan, treated domestic wastewater has to be discharged directly into storm water drains, so the quality of treated water must be consistently high to avoid serious public and environmental health issues.

In its 50-year history of manufacture and sales of wastewater treatment systems, Fuji Clean's innovative R&D scientists and engineers have continuously improved and refined the product into the compact, highly effective, and efficient wastewater treatment system that it is today and helped Fuji Clean Company grow into a world-wide market leader in the onsite wastewater treatment industry.

Fuji Clean USA offers you "boots-on-the-ground" in the U.S. market. We provide final pre-installation assembly and quality control inspection checks on all Fuji Clean systems. We pride ourselves on friendly, respectful and effective customer service, clear communication in all forms and offering first rate training support to your system distributor, contractor and service provider.

## **Service and Support**

Your local distributor will provide you with a trained and certified service provider and a service plan, which will be in effect from the date of system installation. Please contact Fuji Clean USA directly if you need assistance locating your distributor or a certified service provider in your area.

Service providers typically will provide you with a service plan tailored to your system and state and local regulations. At a minimum, here is what you should expect from your Initial Service Policy covering the first two years of your system warranty:

1. Name and contact information for your service provider including emergency contact information. (Note: print this information on the cover of this Manual and be certain that your service provider has affixed contact information to inside of the alarm/control panel.
2. Provisions for 4 inspection/service visits made within 2 years of initial system installation.
3. A service plan that includes a check sheet or inspection report made available after each visit that includes at least the following information:
  - a. Date.
  - b. Purpose of visit.
  - c. Evidence of inspection and specific maintenance to your treatment system (including the air blower).
  - d. Reports of any problem or concern with a plan and schedule for corrective action.
  - e. Report on effluent quality that includes description of effluent color, turbidity, scum overflow and odor.
  - f. A clause that states that the owner shall be notified in writing about improper system operations that cannot be remedied at the time of inspection.
  - g. Information on an extended service policy available for purchase by the owner with terms comparable to those in the initial service policy.

Fuji Clean USA requires that an “Extended Service Policy” is in place following the expiration of the Initial Service Policy (2 years from date of installation). Implementation of the Extended Service Policy shall be provided by a trained and certified service technician (trained by either Fuji Clean USA or one of its distributors).

**System Layout:**

Your Fuji Clean treatment system is designed to accept wastewater directly from your house, clean it using a proprietary “contact filtration” process and prepare it for final discharge such as to a soil absorption leachfield or drainfield. Oxygen, necessary for treatment, is introduced via a Fuji Clean Company manufactured, FujiMAC air blower, which is a state-of-the-art, top-in-class, linear diaphragm air pump. An alarm/controller monitors treatment activity and is triggered if the system floods or the blower stops operating. If an alarm is triggered, your service technician should be notified. A “silence” switch will silence the audible alarm.

Some sites may also include a septic or settling tank prior to treatment, often installed because of local or state requirements and some sites may also include a separate post-treatment pump station if treated water must be pumped uphill for final discharge.

Your Fuji Clean USA system has been engineered to be simple to operate, quiet and hassle-free. It should be inspected and maintained on a semi-annual basis.

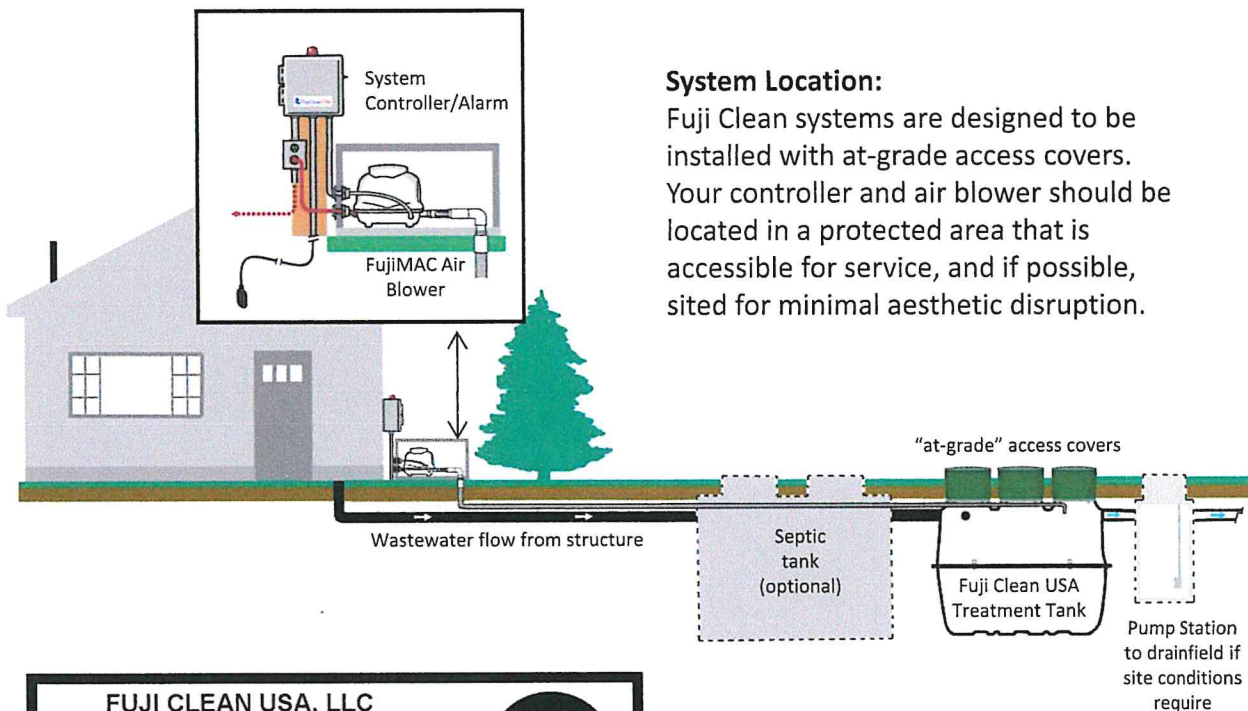

**System Location:**

Fuji Clean systems are designed to be installed with at-grade access covers. Your controller and air blower should be located in a protected area that is accessible for service, and if possible, sited for minimal aesthetic disruption.

<p><b>FUJI CLEAN USA, LLC</b> NSF/ANSI Standard 40 &amp; 245 Class 1 MODEL NO.:XXXXX SERIAL NO.:XXXXX CAPACITY (GPD): XXXXX 41-2 GREENWOOD RD. BRUNSWICK, ME 04011 207-406-2927</p>	
---	--

This NSF label, located both on the control/alarm panel and inside the treatment system (typically on the inside riser) of all Fuji Clean USA systems, indicates that this system meets the requirements set forth in NSF/ANSI Standard 40 & 245, which is a purification performance standard for the treatment of domestic strength wastewater. If you are interested in additional details on this 3<sup>rd</sup> party testing and certification process, please contact Fuji Clean USA, your distributor or NSF International. ([www.nsf.org](http://www.nsf.org)).



# Treatment Process Overview

Fuji Clean's "contact filtration" treatment is a simple, well engineered process that consists of a controlled, circuitous flow train through anaerobic and aerobic chambers and in direct contact with assorted proprietary fixed film medias on which biological digestion of organic matter occurs. Media is also designed and positioned to provide mechanical filtration of process wastewater.

The system includes two air lift pumps (see diagram below) The Recirculating Airlift Pump returns process water and sludge from the aerobic zone to the sedimentation chamber, recirculating 2-4 times inflow per day for CE models and 4-6 times inflow for CEN (enhanced denitrification) models. The Effluent Airlift Pump is designed to help equalize flow and discharge treated effluent.

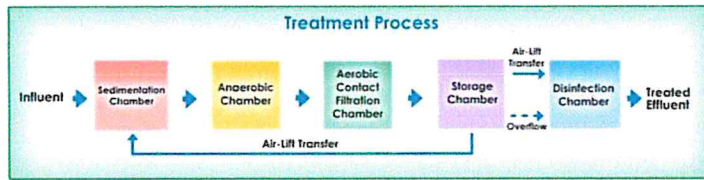

**Two Air Lift Pumps.** One Recirculating Air Lift pump sending process water and solids back to Chamber 1, and one Effluent Air Lift Pump for measured discharge of treated effluent. (See airlift pump info below).

**Chamber 3B. Disinfection Chamber** (final zone before discharge – option for chlorination tablet disinfection)

**Chamber 3A. Storage Chamber** (settling zone)

**Sludge Transfer** (Recirculating air lift pumpback) See airlift pump info below.

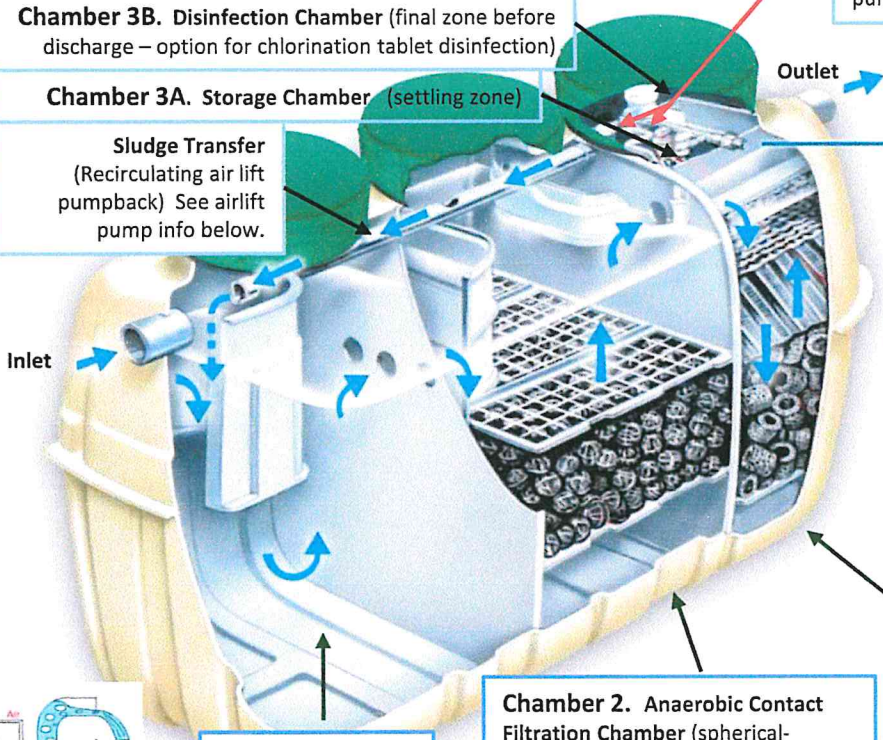

**Powered by the FujiMACR11 Series Blowers** State-of-the-art linear diaphragm air blowers manufactured by Fuji Clean Co sized to provide about 2.8 cubic feet per minute to most residential systems.

**Chamber 3. Aerobic Contact Filtration Chamber** (both board and cylindrical hollow mesh media) oxygen rich zone for aerobic microbe digestion activity, solids filtration and nitrification of ammoniac nitrogens to nitrates

Overflow Effluent Weir

**Chamber 1. Sedimentation Chamber** (separates solids and greases)

**Chamber 2. Anaerobic Contact Filtration Chamber** (spherical-skeleton filter media) organic matter decomposition by micro-organisms, suspended solids captured and nitrates are denitrified

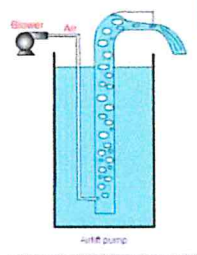

**Airlift Pumps.** This generic illustration shows the mechanics of the "airlift pumps" used in this system, which are simple pipe conduits through which pressurized air (from blower) is introduced at the bottom and by fluid pressure, water is carried up the pipe by ascending bubbles.

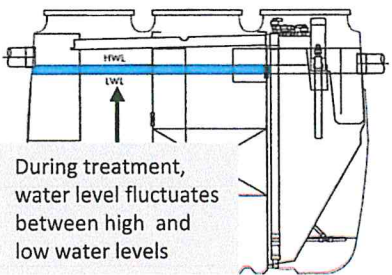

During treatment, water level fluctuates between high and low water levels

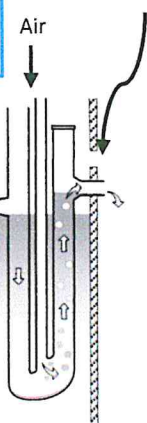

**Flow Equalization** When water level exceeds LWL, treated water is discharged through Chamber 3B via the Effluent Air Lift pump. If water level exceeds HWL, then treated water is also discharged through an overflow effluent weir.

### Which Fuji Clean System Do I Have?

Your system designer or engineer has specified your specific Fuji Clean USA system model based on three main criteria:

1. Wastewater Volume (or Hydraulic Load, typically expressed as gpd, or gallons per day): Usually based on the number of bedrooms in a residential house
2. Wastewater Strength (or Biologic Load): For example, wastewater characteristics from a restaurant will differ and typically be of higher strength than domestic wastewater coming from a residential house.
3. Effluent Requirements: Typically based on state or local regulations, designating how much of what type of pollutants may be discharged to the environment.

Fuji Clean USA has two major residential series models; the CE-Series and the CEN-Series. Both models are designed to remove organic pollutants (as measured by BOD<sub>5</sub>, which stands for "Biochemical Oxygen Demand," and is a measure of the concentration of oxygen, expressed as mg/L, utilized by microorganisms in the oxidation of organic matter during a 5-day period at a temperature of 68-degrees F) and solids (as measured by TSS, Total Suspended Solids, which is the quantity of solids, expressed as mg/L, which can be readily removed from a well-mixed sample with standard laboratory filtering procedures).

While the CE models remove some of the nutrient, Nitrogen, (expressed as TN for Total Nitrogen), from the waste stream, the CEN-Series systems are specifically designed to remove higher levels of nitrogen from the waste stream, hence the "N" designation.

The table below, specifies size, expected measure of treatment based on residential strength waste and the associated size and power draw for each Fuji Clean USA system model.

FUJI CLEAN USA DESIGN SPECIFICATION TABLE	Residential CE Series BOD, TSS, TN*			Residential CEN Series BOD, TSS, TN (Enhanced Nitrogen Removal)		
	Model	CE5	CE7	CE10	CEN5	CEN7
Tank Volume Total (gallons)	544	749	1,069	749	1,069	1,498
Height (inches)	61.8	65.4	73.2	65.4	73.2	77.4
Length (inches)	85	95.7	98.8	95.7	98.8	118.9
Width (inches)	43.7	49.2	56.7	49.2	56.7	68.9
Weight (lbs.)	397	463	705	463	705	926
Inlet Invert (Inches to 1/8")	49	53	61	53	61	62
Outlet Invert (Inches, to 1/8")	47	51	59	51	59	59.5
Blower Size (Standard**)	80 L/min	80 L/min	100 L/min	80 L/min	100 L/min	100 L/min
Power Use (kWh/day)	1.2	1.2	1.7	1.2	1.7	1.7
<p>* TN data was obtained during CE testing, but not to NSF245 testing protocol. CEN testing was to NSF245 protocol.</p> <p>** Assumes blower siting conforms to parameters outlined in Step 8 of this Manual and site is below 10,000 ft. in altitude. If site is above 10,000 ft., please refer to table below for recommended blower sizing.</p>						

## **How to Keep Your System Healthy**

So, you've made an investment in your Fuji Clean treatment system. You have a service provider and service plan. Now, you just have to respect your system and treat it right.

Here's the common-sense bottom line.... Remember that your treatment system is a living system. Billions of living microbes consume pollutants from your wastewater. Excessive fats, oils and greases can smother living microbes. Toxic substances can poison them. Therefore, please refrain from introducing items such as these into your system.

**KEEP THESE ITEMS OUT OF YOUR SYSTEM!  
THEY WILL HARM THE LIVING ORGANISMS  
WORKING TO CONSUME POLLUTANTS FROM YOUR WASTEWATER!**

### **CHEMICALS**

**Excessive Bleach or Laundry Fabric Softeners  
Paint & Paint Thinners  
Herbicides & Insecticides  
Motor Oil and Antifreeze  
Antibiotic Pills  
Chemical De-Clogging Agents (like liquid Draino™)  
Septic System Treatment Products (like Rid-X™)  
Water Softener Backwash  
Cleaning Solutions with Quaternary Ammonium Compounds ("Quat")**

### **TRASH**

**Sanitary Napkins  
Cigarette Butts  
Baby Wipes  
Dental Floss  
Condoms  
Kitty Litter  
Paper Towels**

### **FOOD**

**Excessive Cooking Grease  
Coffee Grounds  
Fruit and Vegetable Peels**

## **GARBAGE DISPOSALS**

Garbage disposals are not recommended for this or any onsite septic system. These devices inject heavy and inconsistent organic loads into the system, which can interfere with normal processing.

## **WELL DISINFECTING**

Sometimes a contaminated well must be disinfected with bleach. In this event, we strongly recommend that you flush chlorinated water from the system through outdoor faucets to prevent an excessive slug of chlorine from entering your treatment system.

### System Components: Controller and Alarm

Your Fuji Clean system is equipped with a simple control panel that monitors system operation. There are two types of events that will trigger an alarm (both audio and visual).

1. High-Water Alarm: Triggered if the water in the tank reaches levels well above standard operating levels. This is a very rare event, but may occur for example if run-off ground water infiltrates the treatment tank or if a post-treatment discharge pump station malfunctions and water backs up.
2. Blower Fault Alarm: Triggered if the air blower stops operating and there is a drop in air pressure to the system.

In either case, if the alarm is triggered, push the toggle switch to “Silence,” and contact your service provider for assistance. If requested, system reference information is posted on the data plate affixed to the alarm controller panel. (See detail) Your service provider may be able to resolve the problem over the phone (for example there may be debris blocking the air intake to the air blower), or may need to come onsite to service the system.

Please note, following an alarm event, the red beacon will remain on while the system is in “silent” mode, until the system controller is reset to run in “Normal” mode.

At any time, you may pull the Toggle Switch to the “Test” position to assure that the light beacon and horn alarm are operating properly. Reset the switch to “Normal” for normal operation.

You may reference the NSF data plate located inside the alarm panel in communication with your service provider.

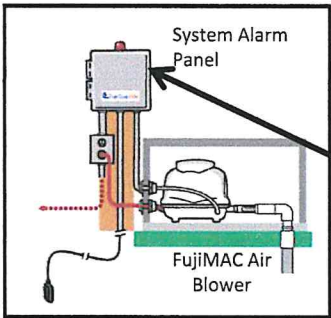

**FUJI CLEAN USA, LLC**  
NSF/ANSI Standard 40 & 245 Class 1  
MODEL NO.:XXXXX SERIAL NO.:XXXXX  
CAPACITY (GPD): XXXXX

41-2 GREENWOOD RD. BRUNSWICK, ME 04011 207-406-2927



### **System Components: FujiMAC Blower**

A separate Owner's Manual is provided for your air blower. Please keep both manuals together and accessible to your system service provider.

### **Frequently Asked Questions:**

**Our system is on our vacation home. Should I turn it off when we are not home?** Fuji Clean systems are designed to accommodate variable and intermittent flows, including only weekend use, but this assume that the air blower operates continuously regardless of inflow. However, for seasonal use properties, the air blower may be shut down if the system is not going to be used for an extended period of time. The blower should be re-started at least three days in advance of system use if possible.

**What if there is a power outage?** During a power outage, the blower will cease operation and after about 24-hours, treatment quality may begin to diminish. However, the Fuji Clean system will still allow wastewater to pass through the system and will not create a backup in the house unless a separate pump station has been installed.

**Does my system need servicing?** Your Fuji Clean system is designed to require minimal service, but inspection and service every 6-months is necessary during the first two years of service to assure proper operation. States vary in terms of mandatory service requirements after the initial 2-year warranty/service period expires, but Fuji Clean USA's extended service policy mandates that your system be maintained properly, which calls for semi-annual inspection/service visits from a trained and certified service provider. (This schedule may be altered for seasonal, and part-time sites). Your certified service provider will review details of initial (first two years) and extended (2 years +) service.

**Does my system need to be pumped out?** Like an ordinary septic tank, sludge must be removed from your system periodically (such as once every 2 years). Your service provider will measure sludge build-up during each inspection and will provide pump-out guidance for you. Pump out frequency depends on waste stream strength and use. Please consult with your service provider to help determine the pump-out frequency that is best for you.

**How much will it cost in electricity to run my system?** Since your Fuji Clean USA system has been designed to operate continuously, it is easy to calculate power cost. All residential units draw 1.1 kWh of power per day except for the CE10, CEN7 and CEN10, which draw 1.6 kWh of power per day. Simply multiply your local cost of power by the draw per day to calculate daily power cost.

### **Can I use a garbage disposal with my system?**

As noted in another section of this manual of how to maintain your system's health, garbage disposals are not recommended for this or any onsite septic system due to the heavy and inconsistent organic loads injected into the system, which can interfere with normal processing. Use of a garbage disposal may increase the frequency of sludge pumpouts.



## **Fuji Clean USA, LLC Limited Warranty**

### **Period of Coverage**

Fuji Clean USA, LLC warrants the parts in each treatment unit to be free of defects in material and workmanship for a period of two years from date of system installation at the site where residential wastewater is to be treated. An Extended Warranty shall be made available by Fuji Clean USA, its authorized dealers or service providers after the initial two-year coverage period.

### **Obligations of Fuji Clean USA, LLC**

At its sole expense, Fuji Clean USA, LLC will service and repair the installed unit including all parts and labor that show evidence of defect or unacceptable performance for any reason when operated within design parameters, provided that all financial obligations of the owner/purchaser are in compliance the Sales Agreement provided by an authorized dealer of Fuji Clean USA treatment systems. Determination of defect or unacceptable performance shall be made by a Fuji Clean USA authorized dealer, distributor and/or service provider.

### **Exclusions**

This Warranty does not apply to Fuji Clean USA units that have been tampered with or altered by unauthorized persons, improperly installed or have been subject to external physical damage or acts of god. Further, this Warranty does not cover systems that have been flooded by external means or damage done by altered or improper wiring or overload protection. Additionally, this Warranty does not apply if the system has been operated beyond its maximum design capacity or permit, if the approved design has been altered after the fact, or if the system has been contaminated with disinfecting tablets, excessive use of bleach or other chemicals injurious to biological growth.

### **Other Provisions**

This Warranty only applies to the Fuji Clean USA, LLC treatment processing system and does not include any wiring, plumbing, drainage, disposal or leaching systems. Fuji Clean USA, LLC or its dealers or authorized service providers also reserves the right, to furnish a component part which, in their judgment, is equivalent to the company part replaced. Further, owner agrees to provide to Fuji Clean USA, or its authorized dealers or service providers with clear access to the processor covers on a year round basis.

Under no circumstances will Fuji Clean USA, LLC be liable for direct or consequential damages including but not limited to lost profits, lost income, labor charges, delays in production or idle production time or habitability which results from any defects in material and/or workmanship of Fuji Clean USA, LLC's system or units.

This Warranty is expressly in lieu of any other expressed or implied warranties. Further, any implied warranties for merchantability and fitness for a particular purpose are hereby disclaimed.

This Warranty provides the owner/purchaser specific legal rights. You may have other rights, which vary from state to state.

## Troubleshooting Guide

This Troubleshooting Guide is provided to help identify system malfunctions or problems. However, please be aware that in most cases, system inspection, maintenance, repair and adjustment requires the services of your trained service provider, whose contact information can be found on the cover of this manual and/or on the inside of your control/alarm panel. System covers should only be opened by a trained and certified service technician!

You are always welcome to contact Fuji Clean USA for additional assistance or if you have comments or questions.

TROUBLESHOOTING	
General	
SYMPTOM	SOLUTION
Water is ponding around risers and covers	Landscaping is necessary (possibly involving addition of fill material) so that water drains away from risers and covers. Note: risers may be added to the unit as necessary, but service personnel must be able to reach into the unit and move controls. Recommended maximum riser height is 24-inches.
Strong and unusual odor exists even with the manhole lids closed.	<p>During the first few weeks of operation there may be noticeable odor from the system. This should cease once the bacteria are established.</p> <p>If odor persists, seeding material may be added to both anaerobic and aeration chambers, and/or the recirculation rate may be increased to 35%, the upper end of the normal operation range.</p> <p>If odor continues to persist, please contact manufacturer for instructions. Installation of a vent may be necessary.</p>
Blower is making an unusually loud noise	Normal blower operation is quiet. Typically a loud or rattling blower noise is created when the blower is in contact with its housing, or has slipped off its base platform.

## TROUBLESHOOTING

### General

SYMPTOM	SOLUTION
Alarm beacon is lit and/or audible alarm horn is sounding.	System alarm is triggered by either too much water flowing through the system or the air from the blower is not reaching the system. Please silence the horn by pushing the toggle switch located on the right side of the alarm/control panel the "Silent" mode. Please call you service technician for assistance. Service technician contact information can be found on the cover of this Manual or on the inside of the alarm/control box. Please note: Alarm beacon will stay lit even if horn is silenced.
There is a water back-up in the house	Fuji Clean systems are equipped with a system overflow relief weir so it is extremely unlikely that a septic system backup is caused by your Fuji Clean system. More likely any backup will be the result of clogging in a preceding septic tank (usually the effluent filter) or possible from a pump station that is not operating. However, a pump station fault should trigger an alarm. Contact your service provider immediately.



## Troubleshooting Guide – for Service Professionals

This Troubleshooting Guide is provided to assist your service professional. A much more detailed guide as well as explanation of service procedures is provided in the Fuji Clean USA Operation and Maintenance Manual. Please do not remove system covers unless you are a trained and certified Fuji Clean USA service technician.

<b>TROUBLESHOOTING</b>	
<b>Chamber 1. Sedimentation Chamber</b>	
<b>SYMPTOM</b>	<b>SOLUTION</b>
Inlet pipe is blocked	Remove the blockage.
Excessive scum accumulations. (Scum layer reaches the top of the influent baffle)	Measure sludge level. If the depth of sludge accumulation is less than 24-inches (or 18-inches in Chamber 2), break the scum layer, otherwise have the plant pumped out.
Excessive sludge accumulations. (Depth of sludge layer exceeds 24-inches)	If the sludge exceeds the holding capacity, have the plant pumped out.
Foreign materials, excessive oil or fat entering the system.	Remind the homeowner to refrain from disposing harmful substances into their system. (Please refer to Homeowner's Manual for listing.)

## TROUBLESHOOTING

### Chamber 2. Anaerobic Filtration Chamber

SYMPTOM	SOLUTION
Excessive scum accumulation. (less than 4-inches)	If Chamber 1, the Sedimentation Chamber still has the remaining sludge holding capacity, (less than 24-inches of sludge build-up), transfer the scum to the sedimentation chamber, otherwise have the plant pumped out.
Excessive scum accumulation. (more than 4-inches)	Have the plant pumped out.
Excessive sludge accumulations	If the bottom sludge layer is thicker than 18-inches and excessive sludge has accumulated on the filtration media, have the plant pumped out.
Filtration media is blocked up. (The water level in Chamber 2's media is lower than that in the baffle.)	<p>Perform a degassing operation on the filtration media. (Poke media with a section of PVC pipe. See O&amp;M procedure #12).</p> <p>If the problem still persists even after the degassing and sludge transfer operation, pressure wash the filtration media using an effluent pump and hose affixed to a PVC pipe.</p>
Foreign materials, excessive oil or fat entering the system.	Remind the homeowner to refrain from disposing prohibited substances and limited-use substances.

# TROUBLESHOOTING

## Chamber 3. Aerobic Contact Filtration Chamber

SYMPTOM	SOLUTION
Bubbles are not evenly distributed throughout the chamber or there are no bubbles at all.	<ul style="list-style-type: none"> <li>• Adjust the aeration control valve.</li> <li>• Check to make sure that there is no leakage from the aeration pipework.</li> <li>• Check to make sure that the blower operates properly.</li> <li>• Clean the aeration pipes</li> <li>• Perform a backwash operation. (O&amp;M Procedure #12).</li> </ul>
Dissolved Oxygen is less than 1.0mg/L.	<ul style="list-style-type: none"> <li>• Check to make sure that the blower operates properly.</li> <li>• Perform a backwash operation. (O&amp;M Procedure #12).</li> </ul>
Recirculation rate is unable to be adjusted or no recirculation at all.	<ul style="list-style-type: none"> <li>• Adjust the recirculation control valve.</li> <li>• Check to make sure that there is no leakage from the aeration pipework.</li> <li>• Check to make sure that the blower operates properly.</li> </ul>
Recirculation flow rate is too high	<ul style="list-style-type: none"> <li>• Clean the aeration pipes</li> </ul>
Recirculation flow rate is too low	<ul style="list-style-type: none"> <li>• Clean the recirculation airlift pump.</li> </ul>
Excessive foaming.	<ul style="list-style-type: none"> <li>• Some foaming may occur during the early stage of operation.</li> </ul> <p>This should cease once the bacteria are established. Seeding may also be effective. Please contact your distributor for additional seeding information.</p>
Excessive suspended solids.	<ul style="list-style-type: none"> <li>• Perform a backwash operation.</li> </ul>
Cold water is hampering treatment	<p>The following measures will allow greater oxygen penetration into biofilm.</p> <ul style="list-style-type: none"> <li>• Increase frequency of backwash</li> <li>• Increase blower size</li> <li>• Perform desludge operation (i.e. sludge pumpout)</li> </ul>

## TROUBLESHOOTING

### Chamber 3a. Storage Chamber

SYMPTOM	SOLUTION
Scum forming.	<ul style="list-style-type: none"><li>• Transfer the scum to Chamber 1, the Sedimentation Chamber, using a pump, ladle or suitable container.</li><li>• Increase the recirculation rate (within the normal operating range).</li></ul>
Excessive sludge accumulations.	<ul style="list-style-type: none"><li>• Transfer the sludge to Chamber 1, the Sedimentation Chamber, using a pump, ladle or suitable container.</li></ul>
pH is too low or too high. (pH < 5.8 or pH > 8.6)	<ul style="list-style-type: none"><li>• Check to make sure the recirculation rate is appropriate.</li><li>• Remind homeowner of what cannot be put into this system (refer to Homeowner's Manual).</li><li>• Install a slow-release lime dispersal system into the sedimentation chamber to raise the pH. Please contact Fuji Clean USA for details.</li></ul>
Excessive biofilm on the chamber wall.	<ul style="list-style-type: none"><li>• Clean the wall with brush or water pressure and transfer solids to the sedimentation chamber.</li></ul>
Effluent airlift pump is not working.	<ul style="list-style-type: none"><li>• Clean the airlift pump.</li><li>• Flush the effluent control valve.</li><li>• Check to make sure there is no leakage from the blower pipework.</li><li>• Check to make sure that the blower operates properly.</li></ul>

# TROUBLESHOOTING

## Air Blower

### What to observe

### Status

### How to solve the problem

#### Blower is not working

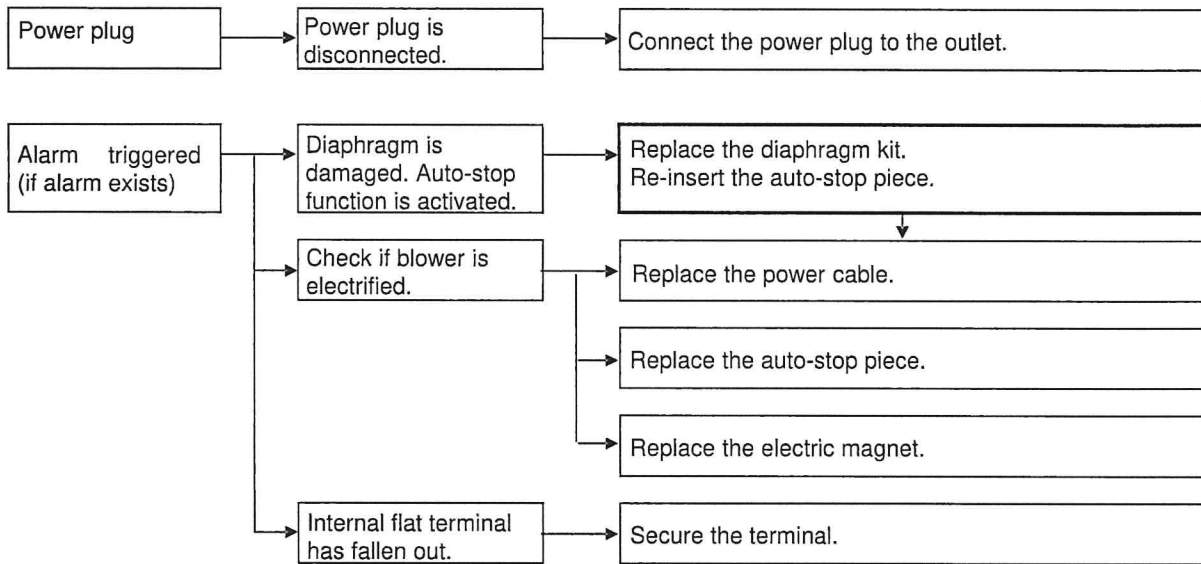

#### Blower is making an abnormal or excessive operating noise.

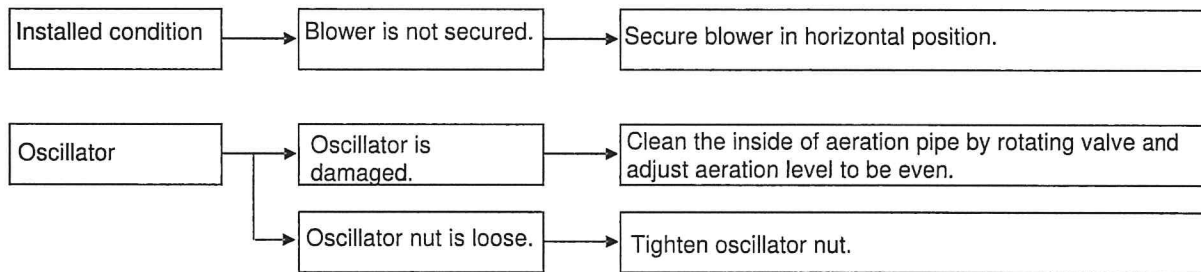

#### Low air volume or misplaced air from aeration pipes (treatment plant)

