

ARTICLE X, SECTION 10.4

BUILDING STANDARDS

PURPOSE

- To provide buildings that reflect the scale and character of buildings within the community.
- To allow for flexible building expansion to increase floor area.
- To allow for attached or detached accessory buildings to provide additional usable space.
- To allow additional buildings and structures to be provided on a lot.

CONTENTS

A. GENERAL BUILDING STANDARDS

1. Number of Buildings	10.4-2
2. Nonconforming Buildings	10.4-2
3. Building Assembly	10.4-3
4. Roofs	10.4-5
5. Components	10.4-5
6. Height	10.4-6
7. Building Orientation	10.4-7
8. Building Elevation	10.4-7
9. Fenestration	10.4-8
10. Primary Entrances	10.4-9
11. Shopfronts	10.4-9
12. Building Articulation	10.4-10
13. Slopes & Terraces	10.4-10
14. Liner Buildings	10.4-11
15. Mezzanines	10.4-11

B. PRIMARY BUILDING TYPES

1. Informal Building	10.4-13
2. Cottage	10.4-14
3. House	10.4-16
4. Bungalow	10.4-18
5. Duplex	10.4-20
6. Apartment House	10.4-22
7. Apartment Building	10.4-24
8. Townhouse	10.4-26
9. Shophouse	10.4-28
10. Live/Work Flex	10.4-30
11. Shop	10.4-32
12. Inn	10.4-34
13. Fabrication Building	10.4-36
14. Mixed-Use Building	10.4-38
15. Civic Building	10.4-40

C. ACCESSORY BUILDING TYPES

1. Barn	10.4-44
2. Farmstand	10.4-46

APPLICABILITY

- This section applies to the construction of all new buildings, building renovations, and building additions in the Village Center District.
- This section applies to single-family detached dwelling units in a Pocket Neighborhood.
- This section does not apply to a single-family detached dwelling, but may be used as advisory guidelines.

3. Carriage House	10.4-48
4. Fabrication Shop	10.4-50
5. Accessory Shop	10.4-52

D. COMPONENTS

1. Porch	10.4-54
2. Gallery	10.4-54
3. Side Wing	10.4-55
4. Rear Addition	10.4-55
5. Stoop	10.4-56
6. Connector	10.4-56
7. Cross Gable	10.4-57
8. Shed Dormer	10.4-57
9. Dormer Window	10.4-58
10. Bay Window	10.4-58
11. Balcony	10.4-59
12. Extended Shopfront	10.4-59
13. Turret	10.4-60
14. Arcade	10.4-60
15. Porte-Cochere	10.4-61
16. Portico	10.4-61
17. Canopy	10.4-62
18. Deck	10.4-62
19. Tower	10.4-63
20. Roof Deck	10.4-63
21. Cupola	10.4-64

E. ROOF TYPES

1. Gable Roof	10.4-66
2. Hipped Roof	10.4-68
3. Mansard Roof	10.4-70
4. Gambrel Roof	10.4-72
5. Shed Roof	10.4-74
6. Flat Roof	10.4-76

F. SPECIAL DEFINITIONS

1. Definitions	10.4-78
----------------------	---------

1. NUMBER OF BUILDINGS

PURPOSE

- To be able to effectively regulate the number of buildings allowed on a lot.

APPLICABILITY

- Applies to all buildings and accessory buildings.



A. GENERAL

1. Multiple primary buildings may be built on each lot.
2. Multiple accessory buildings may be built on each lot.
3. An accessory building may not permanently occupy a lot without a primary building except:
 - a. On lots actively used for agricultural uses, the barn accessory building may occupy a lot without a primary building.
 - b. An accessory building may be built on a lot prior to a primary building only if both the primary and accessory buildings have been permitted according to the standards of this Section.

2. NONCONFORMING BUILDINGS

PURPOSE

- To allow for the flexible modification, adaption, reuse, and expansion of buildings that existed prior to and were made non-conforming by this Ordinance.

APPLICABILITY

- Applies to all buildings, accessory buildings, and additional structures that existed prior to the adoption of this Ordinance, and that do not meet all the standards of this Article.



A. GENERAL

1. Routine repair and maintenance of nonconforming buildings is permitted.
2. Nonconforming buildings may be altered to eliminate or reduce a nonconformity or to create a conforming building type that meets the standards of this Ordinance.
3. The width and length of the main building mass of a nonconforming building may be expanded within the allowed setbacks of the district and to the extent permitted by the assigned building type.
4. A nonconforming building may be increased in height to the extent permitted by the assigned building type, except when the floor to ceiling heights of the nonconforming building are greater than those allowed for the assigned building type.
5. Nonconforming buildings may be expanded by adding components that meet the standards of this Ordinance, except when the main building mass exceeds either of the maximum width and length dimensions permitted by the assigned building type. In this case, the total square footage of the building may not exceed the sum of the square footage that would be permitted for a main building mass, rear wing, and side wing of the same building type.
6. When nonconforming buildings are expanded with permitted massing components, floor height standards may be waived to allow floor heights to match.
7. When nonconforming buildings are expanded, windows, doors, and roof shape may take the form of the nonconforming building.
8. A nonconforming building may not be moved in whole or part to another location unless the building conforms to the standards of the district to which the building is moved.
9. When the main building mass of a nonconforming building is destroyed and requires total replacement, the building must be rebuilt to meet the standards of this Ordinance.
10. When any portion of a nonconforming building is damaged and does not require a total reconstruction, it may be repaired and rebuilt to its previous condition.

11. Where a nonconforming building, including the main building mass or components, encroach into setbacks, the building may be expanded vertically so long as the additions and modifications otherwise meet the standards of this Ordinance.

3. BUILDING ASSEMBLY

PURPOSE

- **To provide a clear and flexible system for enabling the construction of new buildings and the expansion and modification of existing buildings**
- **To allow for a broad range of building designs.**

APPLICABILITY

- **Applies to all primary buildings and accessory buildings**



A. GENERAL

1. All primary and accessory buildings must meet the standards for one of the building types provided within this Ordinance.
2. Each primary building and accessory building must be comprised of a main building mass with a rectangular form and a single allowed roof type.
3. The following building types are not required to take a rectangular form but must meet standards for building dimensions, height, and setbacks: inn, civic building, and fabrication building.
4. The outer wall of a main building mass must be located entirely in a single plane. Deviations to the wall plane are allowed only through permitted articulations.
5. For the purpose of measurement, building length and width standards apply only to the main building mass of primary and accessory buildings. Components have unique dimensions and standards.
6. Integral components may be used to cut away space within the boundaries of the roof or main building mass provided the eaves and ridge beam of the roof are not affected.

B. ATTACHMENTS

1. Primary buildings may only attach to other primary buildings (or to their components) the number of times indicated in Section B Primary Building Types.
2. Accessory buildings may only attach to primary buildings or other accessory buildings (or to their components) the number of times indicated in Section C Accessory Building Types.
3. Components may attach to primary and accessory buildings.
4. A building may not encroach on setbacks in order to attach to an adjacent building.
5. Primary buildings may attach to other primary buildings or to the components of other primary buildings on no more than two sides.
6. Primary buildings that are allowed to attach to other primary buildings may do so on side or rear walls only.

7. Where a building is allowed to attach to other buildings (or to its component), only one building or component may attach to each building face.
8. Permitted attachments may occur across theoretical or legal lot lines.
9. Where two primary buildings attach, the division between buildings must be apparent on the building's exterior through seams in materials, downspouts, pilasters, buttresses, or other vertical structural elements that are less than 6 horizontal inches from the surface of a building's facade.
10. A group of attached buildings, including their components, must provide gaps or breaks in the street wall at intervals no greater than 180 ft (measured from the centerline of the break) along any frontage. These gaps may consist of on-site civic space, a pedestrian or service thoroughfare, an extension of the adjacent sidewalk, or narrow side yards.
11. Breaks must measure at least 3 ft and no more than 12 ft in width when separating two buildings that do not share internal circulation.
12. Where breaks are required between two attached buildings that share circulation, the hyphen component may be used to bridge the resulting gap between the two buildings provided that through-block access is maintained at ground level through a public lobby, passage, or archway and the hyphen is set back at least 10 ft from the frontage.
13. Breaks must measure at least 10 ft and no more than 12 ft in width when separating two buildings that share internal circulation.
14. A group of attached buildings, including their components, that share internal circulation are limited in aggregate length to no more than 180 ft along any frontage.
15. When a group of attached buildings that share internal circulation includes a corner building, the corner building is limited in width to 70 ft along the secondary frontage. Any additional gap between buildings may be closed using a side wing or rear addition that has a roof type that is distinct from the main building mass.

C. INTERNAL CIRCULATION

1. Buildings must maintain an independent structural system, with the exception of party walls, which are shared.
2. Breaks in a party wall between two attached buildings may only occur in order to share circulation, corridors, stairwells, and elevators.
3. First floor commercial units may share a unit between two or more attached buildings by special permit.
4. Party walls must be structural, load bearing, and extend through the width of both buildings to form a continuous wall.
5. The soffit along the frontage of a building may not encroach on a neighboring building lot.

D. NUMBER OF UNITS

1. Buildings have a maximum number of units as regulated in Section B Primary Building Types and Section C Accessory Building Types.
2. If a permitted accessory building cannot be constructed due to site restrictions or other design related concerns, the accessory unit associated with the accessory building may be incorporated into the primary building, provided the total area of the accessory unit does not exceed either 30% the area devoted to the building's primary unit, or the maximum floor area of the permitted accessory building, whichever is smaller.

4. ROOFS

PURPOSE

- To provide for buildings that have identifiable roof shapes based on local character.

APPLICABILITY

- Roof standards apply to all primary and accessory building types and components, with the exception of the civic building, which may have more unique and complex assemblies.



A. GENERAL

1. The primary building mass, accessory building, or component may only employ one roof type.
2. Pitched roofs must converge, symmetrically, to a single ridge beam at their highest point.
3. Shed roofs are considered to be symmetrical provided the vertical separation between the base of the eaves and the top of the ridge beam is the same across the entire length of the roof.
4. Asymmetrical roof assemblies are prohibited.
5. The upper slope of mansard and gambrel roof profiles must always be less steep than the lower slope.
6. The highest point of the roof of any component must be lower than or equal to the highest point of the roof of the primary building, unless specifically allowed to be taller.
7. Gable ends must be located on the narrowest building face or component face, except for townhouses, live-work/ flex buildings, and bungalows, which must orient the ridge beam parallel with the frontage.

B. NONCONFORMING ROOFS

1. Routine repair and maintenance of nonconforming roofs is permitted.
2. Nonconforming roofs may be altered to eliminate or reduce a nonconformity or to create a conforming roof that meets the standards of this Ordinance.
3. When a nonconforming roof is damaged or destroyed, it may be repaired or rebuilt to its previous condition.
4. Accessory buildings and components added to nonconforming buildings may use a roof that takes the form and pitch of the nonconforming primary building.

5. COMPONENTS

PURPOSE

- To provide a clear and flexible system for enabling the construction of new buildings and the expansion and modification of existing buildings.

APPLICABILITY

- Applies to all primary buildings and accessory buildings



A. GENERAL

1. At least one component is required per primary building except on the mixed-use building.

B. ATTACHMENTS

1. All components may attach to other components, unless otherwise indicated.
2. All components are allowed to stack on top of one another, unless otherwise indicated.
3. Multiple components of the same type may be used more than once, unless otherwise indicated.
4. Multiple components of the same type may not attach to each other, unless specifically allowed, and must be separated horizontally by a distance of no less than 1 ft.
5. Two components may not occupy the same space (overlap), unless specifically allowed in Section D Components.
6. Any enclosed component that is permitted to extend flush with a side or rear lot line is permitted to attach to a neighboring structure also built flush to the same lot line.

C. ENCROACHMENTS

1. Components may encroach their entire width and/or depth into all setbacks, unless specifically disallowed in Section D Components.
2. Components may be allowed to encroach into the public right-of-way with authorization from the Permitting Authority.

D. NONCONFORMING COMPONENTS

1. Routine repair and maintenance of nonconforming components is permitted.
2. Nonconforming components may be altered to eliminate or reduce a nonconformity or to create a conforming component that meets the standards of this Ordinance.
3. The dimensions of a nonconforming component may be

expanded within the allowed setbacks of the district and to the extent permitted by the assigned component type.

4. When a nonconforming component is destroyed and requires total replacement, the component must be rebuilt to meet with the standards of this Ordinance.
5. When any portion of a nonconforming component is damaged and does not require a total reconstruction, it may be repaired and rebuilt to its previous condition.

E. FIRE ESCAPES

1. Fire escapes may be added to existing buildings when no other means of providing egress is possible or practical.
2. Exterior fire escapes may encroach upon side and rear setbacks only.
3. Sizing and location of fire escapes must meet all local and state fire codes.

6. HEIGHT

PURPOSE

- **To create a predictable and clear approach to measuring and regulating height of buildings.**

APPLICABILITY

- **Applies to all new buildings or modifications to existing buildings that increase the overall height of the structure.**



A. STORY HEIGHT

1. Building height in this Ordinance is measured in stories.
2. Story height is measured from the surface of any floor to the surface of the floor above it or, if there is no floor above, from the surface of the floor to the top of the wall plate.
3. For buildings with pitched roofs, habitable space is allowed within the pitch and is not considered a story.
4. A building that has more than one floor contained within the structure of a pitched roof must count all but the top floor as a story.
5. A habitable floor within a pitched roof must be counted as a story if the roof rafters intersect the wall plate or top of the exterior wall frame at a height more than 2 feet above the finished floor of the space.
6. Basements are counted as a story when 5 feet or more of an exterior wall located within the frontage zone is exposed above the average ground level.
7. In the event that floor heights vary in different parts of the same building, such that multiple stories in one area equate in height to one story in another, the shorter floor-to-floor height should be used to determine number of stories, provided that none of the floors are mezzanines.

B. HEIGHT EXCEPTIONS

1. Maximum height standards do not apply to mechanical equipment; vents or exhausts; solar panels or skylights; flagpoles; chimneys; parapets; or other non-habitable architectural features.
2. The maximum heights of roof decks, towers, turrets, and cupolas are regulated in Section D Components.
3. Maximum height standards for Amateur (HAM) Radio Equipment, and wireless telecommunications facilities are regulated by other Articles within this Ordinance.

7. BUILDING ORIENTATION

PURPOSE

- To ensure that buildings address the street in a way that reinforces or creates the character desired in a neighborhood.
- To enable people to access the fronts of buildings.
- To provide consistent placement of buildings within a neighborhood.

APPLICABILITY

- Applies to all new primary buildings, accessory buildings, and components.



A. GENERAL

1. All primary buildings must front on a primary thoroughfare, with the exception of cottages, bungalows and townhouses, which may front on alleys or civic space.
2. The facade of all primary buildings and accessory buildings, and massing components must have the same orientation.
3. Buildings must be oriented parallel to the primary frontage line, with the following exceptions:
 - a. In the case where a thoroughfare bends, a building may take the orientation of adjacent buildings or orient toward the corner, at an angle determined by drawing an imaginary line between the endpoints of the two side lot lines along the frontage.
 - b. Buildings that are part of a Pocket Neighborhood must be oriented parallel to the civic space they face.
 - c. Building orientation may rotate by 22.5 degrees by waiver, based on demonstrating that natural landscape features preclude meeting building orientation standards and that those features were not man-made, modified, or adjusted.

8. BUILDING ELEVATION

PURPOSE

- To ensure that buildings with first floor residential uses are raised above the level of the ground as a way to protect privacy where buildings are located close to the street.
- To ensure that buildings with first floor commercial spaces are located at grade to the extent possible to provide accessible shopfronts.

APPLICABILITY

- Applies to all new primary buildings and accessory buildings with residential first floor units.



A. GENERAL

1. Buildings must be elevated along their primary frontage to meet first floor elevation requirements of each primary and accessory building type.
2. Buildings that are located within 10 ft of a frontage line must have the first floor at the same grade or higher than the abutting sidewalk.
3. Primary buildings that contain dwelling units on a first floor frontage must be elevated above grade a minimum of 2 ft along the frontage, except for the following, which may be built at grade:
 - a. Live/work flex buildings.
 - b. Accessory buildings.
4. First floor elevation is measured from the average ground level at the front of the building to the top of the finished floor of the first story of a building.

9. FENESTRATION

PURPOSE

- To ensure that buildings relate to the street by providing a rhythm of door and window openings.
- To minimize blank walls along thoroughfares to keep eyes on the street.

APPLICABILITY

- Applies to all new primary buildings, accessory buildings, and components, not including civic buildings.

A. GENERAL

1. Fenestration requirements apply to all building facades, except where installation of windows along side or rear property lines is infeasible due to separation requirements mandated by the fire code.
2. The required fenestration percentages apply to the total area of each story of each building facade as measured from the surface of the floor of that story, to the surface of the next floor above; or, if there is no floor above, to either the top of the wall plate, or the base of the buildings eaves, whichever is shorter.
3. Windows and doors must have clear, transparent glass that has a minimum Visible Light Transmission of 50% as indicated by the glass manufacturer.
4. All windows and doors on a building face must be square or vertical in proportion and must have center or edge alignment that is vertical and horizontal, except as follows:
 - a. Stairwell windows may be circular, or take the shape of any regular polygon, other than a triangle, taking the orientation of the roof pitch.
 - b. Shopfront windows are exempt.
5. Lifting, swinging, or sliding carriage house doors are not permitted within the frontage zone, except for:
 - a. On commercial building facades, where doors must be comprised of 50% transparent glass, with multiple vertically proportioned windows or window lights combined to create horizontal compositions.
 - b. On accessory buildings.
 - c. On civic buildings.
6. Residential sliding doors and windows are prohibited along frontages.
7. Window and door openings may not vertically span more than one story, including floor structures or mechanical systems.
8. Entrances to basements may not be located within the frontage zone.

9. To the extent possible, window and door patterns and window configurations should be used to break the direct line of sight between neighboring properties to minimize privacy impacts.

B. NONCONFORMING FENESTRATION

1. Routine repair, maintenance, and replacement of nonconforming windows and doors is permitted.
2. Nonconforming windows and doors may be altered to eliminate or reduce a nonconformity or to create conforming windows and doors that meet the standards of this Ordinance.
3. Accessory buildings and components added to nonconforming buildings may use window and door patterns that take the form and rhythm of the nonconforming primary building.

10. PRIMARY ENTRANCES

PURPOSE

- To ensure that buildings are accessible from thoroughfares as a way to encourage pedestrian activity.
- To prevent extended blank walls that can cause a street to feel uncomfortable for pedestrians.

APPLICABILITY

- All new primary buildings and accessory buildings.
- Modifications to existing buildings that include a change in use to a commercial use.



A. GENERAL

1. At least one primary entrance must be located along the primary frontage of a primary building's main building mass.
2. Cottages, houses, apartment houses, and duplexes may have their primary entrance on the side of a primary building's main building mass, provided the side door is located within the frontage zone.
3. Primary entrances must provide both ingress and egress and be operable and permanently clear at all times.
4. On buildings that contain commercial uses, entrance doors must be provided at intervals of no greater than every 30 linear feet along first floor facades.
5. Primary entrance spacing requirements must be met for each building individually, in that doors on adjacent buildings may not be used to meet the spacing requirement.
6. Primary entrance spacing is measured as the distance between the center line of doors along a facade.

11. SHOPFRONTS

PURPOSE

- To ensure that areas intended for commercial activity have a shopfront treatment that supports business vitality.

APPLICABILITY

- The first floor facade of new primary and accessory buildings including shophouses, mixed-use buildings, shops, accessory shops, and extended shopfronts.



A. GENERAL

1. Shopfronts must provide doors and windows with a minimum of 70% glazing.
2. Shopfronts may include carriage house doors that meet the glazing requirements.
3. Buildings on corner lots with shopfronts must extend shopfront fenestration a minimum of 12 feet along the secondary frontage.
4. Entrance doors into publicly-accessible commercial units must be provided at intervals of no greater than every 25 linear feet along first floor facades.
5. Glazing percentage requirements are based on the surface area of the shopfront. Shopfront surface area is the first floor height multiplied by the total width of the first floor of a building, measured at the frontage.
6. The area of a commercial unit is determined by the first floor height multiplied by horizontal distance between the interior walls of the unit, measured at the frontage.
7. Where a shopfront does not extend across a building's entire facade, the area of the shopfront must be determined by the first floor height multiplied by the total width of the commercial unit.

B. NONCONFORMING SHOPFRONTS

1. Routine repair and maintenance of nonconforming shopfronts is permitted.
2. Nonconforming shopfronts may only expand along a frontage if primary entrance, door and window, and building type standards are met.

12. BUILDING ARTICULATION

PURPOSE

- To enable buildings that contribute to the overall character of a street.
- To minimize exaggerated building articulations that can interrupt pedestrian movement and result in a disorienting built environment.

APPLICABILITY

- Applies to new buildings.

A. GENERAL

1. Architectural features and small articulations less than 6 horizontal inches from the surface of a building's facade are permitted.
2. Forecourts are permitted on mixed-use buildings, apartment buildings, fabrication buildings, and civic buildings, provided they meet the following standards:
 - a. Only one building facade may have a forecourt.
 - b. Forecourts must provide access to the first floor of a building with the same frequency of windows and doors as the facade it is associated with.
 - c. The width of a forecourt must be no greater than 1/3 of the building face to which it is associated.
 - d. The maximum depth of a forecourt must maintain a ratio of 1:1 with the height of the associated building face, measured from the surface of the forecourt to the base of the eaves or top of the parapet.
 - e. The average elevation of the floor of a forecourt must not exceed 1 ft above the abutting sidewalk.
 - f. Courtyards located away from the frontage are allowed for mixed-use buildings, apartment buildings, fabrication buildings, and civic buildings, but their dimensions, shape, and size are not regulated by this Ordinance.
 - g. Arcades, may extend across the gap created by a forecourt to create a peristyle, provided they are not enclosed by glass, railings, or other physical obstructions.
3. Corner buildings with first floor shopfronts may have a chamfered corner, provided the length of the resulting chamfer face is less than 12 feet and that both edges of the chamfer are equidistant from the corner.
 - a. Chamfered corners must provide an entrance. This entrance may not be counted toward the primary entrance spacing requirement.
 - b. Mixed use buildings may extend the chamfer to upper stories as desired. All other building types must limit the chamfer to the first floor only.

13. SLOPES & TERRACES

PURPOSE

- To ensure that buildings located in mixed-use areas meet the sidewalk.
- To allow terraces as a way to provide pedestrian circulation adjacent to shopfronts on streets with steep slopes.

APPLICABILITY

- Applies to new buildings or existing buildings that want to construct a terrace.

A. GENERAL

1. Buildings with a 0 ft front setback must provide entrances at grade to the abutting sidewalk.
2. Shopfronts must step down entrances to meet the grade of the adjacent sidewalk along the frontage.
3. If a building with a 0 ft setback is located on a sloped frontage, the first floor of each commercial unit must match the average elevation of the abutting sidewalk along the frontage of each commercial unit.
4. When the grade of a thoroughfare at a primary or secondary frontage has a slope of 10% or greater, the adjacent buildings may provide a level terrace in their front setback.
5. The following standards apply to buildings that are set back less than 12 ft from the street:
 - a. The terrace must be paved to match the adjacent sidewalk.
 - b. A railing or low wall must be provided wherever the terrace is elevated more than 1 ft above grade.
 - c. Stairs may be provided between abutting terraces to promote pedestrian circulation along shopfronts.
 - d. When applied, terraces must extend along the entire frontage of the building.
6. The following standards apply to all buildings with a setback greater than 12 ft:
 - a. The terrace must be surfaced with grass or other vegetation with the exception of permitted patios, or driveways, sidewalks, or walkways that cross the terrace.
 - b. The lot may be terraced for all, or a portion, of its frontage.
 - c. The terrace may provide steps to the adjacent sidewalk anywhere along the frontage.

14. LINER BUILDINGS

PURPOSE

- Liner buildings are a tool to help create or maintain an active and safe street.

APPLICABILITY

- Liner building standards apply to any building, use, or lot where a liner building is used to provide parking lot screening.



A. GENERAL

1. Buildings that may be used as liner buildings include, the mixed use building, townhouse, and live/work flex.
2. Liner buildings must be placed between the building, lot, or use being lined, and the abutting thoroughfare according to the following standards:
 - a. The total length of liner buildings along a facade being lined should be at least 50% the length of that facade.
 - b. Gaps in the liner may not exceed 20 ft in continuous length.
 - c. Liner buildings are only required along the ground floor frontage of the building, lot, or use being lined, but may extend taller.
3. Liner buildings may occupy the same lot as the building, lot, or use being lined, and may share internal circulation, structural system, and individual units between them in the manner of a single building.

15. MEZZANINES

PURPOSE

- To allow partial floors.

APPLICABILITY

- Applies to construction of mezzanines in new buildings or existing buildings.



A. GENERAL

1. Publicly accessible mezzanines may be provided within a building story with the following standards:
 - a. A building story must be at least 18 ft in height to accommodate a public mezzanine.
 - b. A public mezzanine must have a ceiling height of at least 8 ft measured from the finished floor of the mezzanine to the surface of the finished ceiling or underside of the structural members of an unfinished ceiling.
 - c. The area of a public mezzanine may be no greater than 50% the area of the main floor beneath it.
2. Utility or mechanical mezzanines, intended only for access by repair personnel, may be provided within a full building story with the following standards:
 - a. A building story must be at least 15 ft in height to accommodate a mechanical mezzanine.
 - b. Mechanical mezzanines may be designed as a crawlspace, and have a minimum ceiling height of 4 ft.
 - c. Mechanical mezzanines may be no greater than 75% the area of the main floor beneath them.
3. From the exterior of the building, mezzanines should appear like part of the story they are associated with. A mezzanine may not appear like a complete building story from the outside.

TABLE B - BUILDING TYPE SUMMARY

1. INFORMAL BUILDING

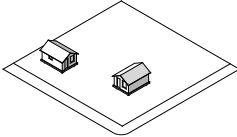

2. COTTAGE

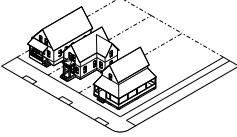

3. HOUSE

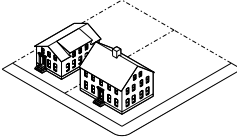

4. BUNGALOW

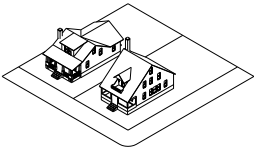

5. DUPLEX

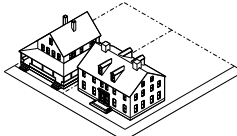

6. APARTMENT HOUSE

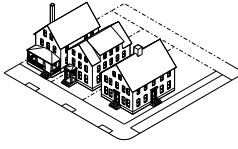

7. APARTMENT BUILDING

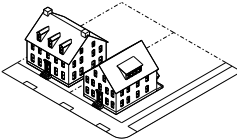

8. TOWNHOUSE

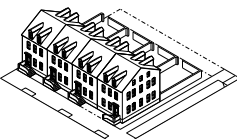

9. SHOPHOUSE

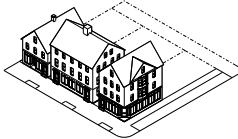

10. LIVE/WORK FLEX

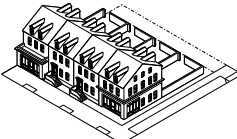

11. SHOP

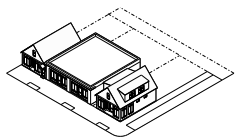

12. INN

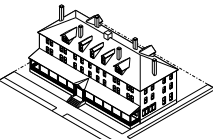

13. FABRICATION BUILDING

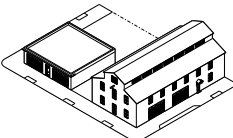

14. MIXED-USE BUILDING

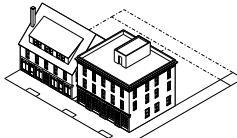

15. CIVIC BUILDING



1. INFORMAL BUILDING

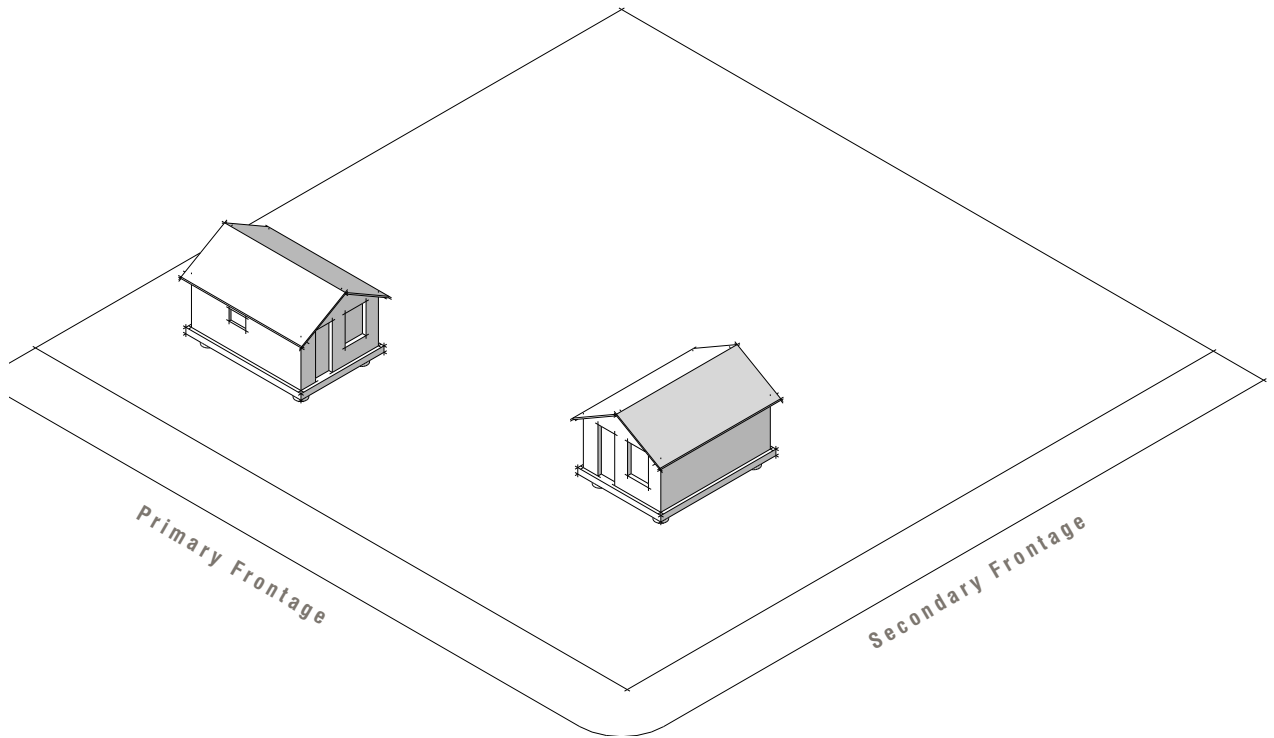

a. DESCRIPTION

A light imprint, low impact, temporary, and informal building that enables creative use of property, including shacks, yurts, cabins, lean-tos, a-frames.

b. BUILDING FORM

Building Floor Plate	500 sf max
Total Stories	1 max
First Floor Height	12 ft max
First Floor Elevation	n/a
Roof	see Section E Roof Types
Attachments	none

c. ALLOWABLE UNITS

1 unit max

d. WINDOWS & DOORS

First Floor Fenestration	n/a
Upper Floor Fenestration	n/a

e. STANDARDS

1. Informal buildings may function as a primary or accessory building.
2. The total aggregate area of informal buildings on a single lot (or series of adjacent lots in common ownership) may not exceed 5,000 sf.
3. Informal buildings do not need to front onto a thoroughfare.
4. For a structure to be considered an informal building it must meet any three of the following four standards.
 - a. Building is less than 500 SF total.
 - b. Building has no permanent physical connection to off-site water, electrical, or sewage utilities.
 - c. Building has no insulation.
 - d. Building has no permanent foundation. Informal foundations may consist of:
 - i. Jacks, blocks, or piers that rest on the surface of the bare ground.
 - ii. A chassis with independent suspension and axles capable of free rotation.
 - iii. Any other type of foundation that may be de-constructed and removed with minimal site disturbance, and with little need for heavy machinery or invasive techniques.

2. COTTAGE

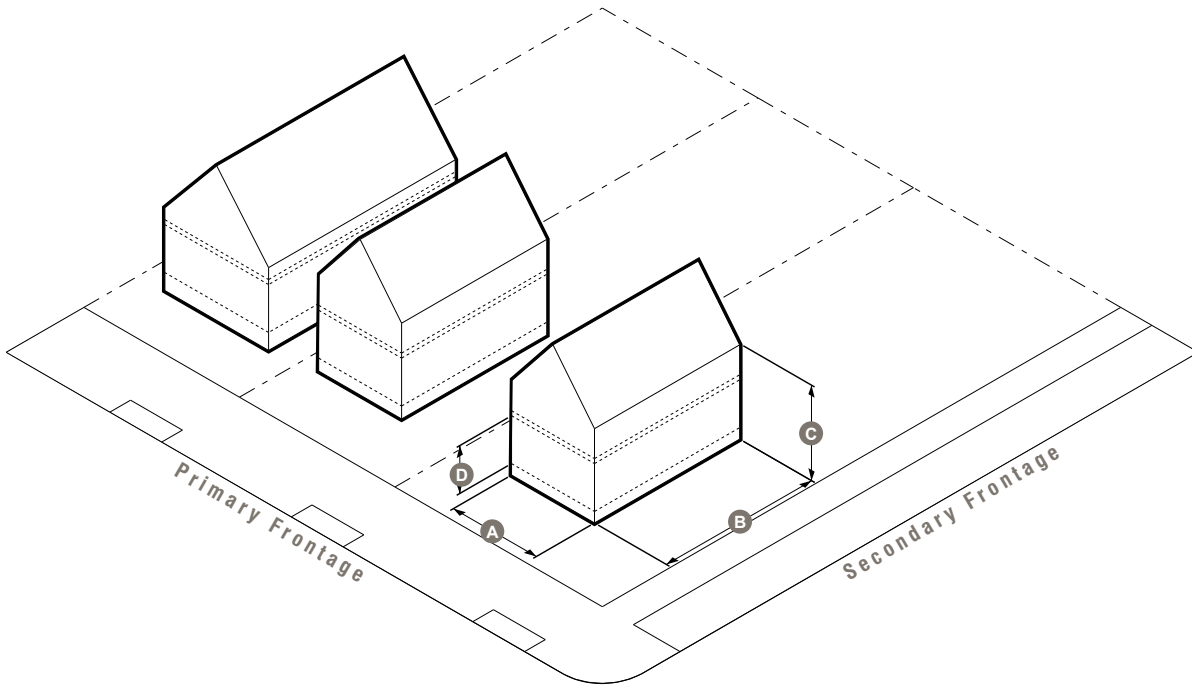

a. DESCRIPTION

A small detached building with one unit.

b. BUILDING FORM

Building Width	14 ft min, 20 ft max	(A)
Building Length	40 ft max	(B)
Total Stories	1 story max	(C)
First Floor Height	9 ft min, 10 ft max	(D)
Upper Floor Height	n/a	(E)
First Floor Elevation	2 ft min	
Components	see Section D Components	
Roofs	see Section E Roof Types	
Attachments	none	

c. ALLOWABLE UNITS

1 unit max

d. FENESTRATION

First Floor Fenestration	20% min
Upper Floor Fenestration	20% min

e. STANDARDS

1. A Cottage may possess a chassis with independent suspension and axles capable of free rotation, provided:
 - a. The Cottage has a permanent connection to water, sanitary, and power utilities.
 - b. The chassis is screened in such a way as to be indistinguishable from a traditional foundation.
 - c. The Cottage may not encroach on setbacks.

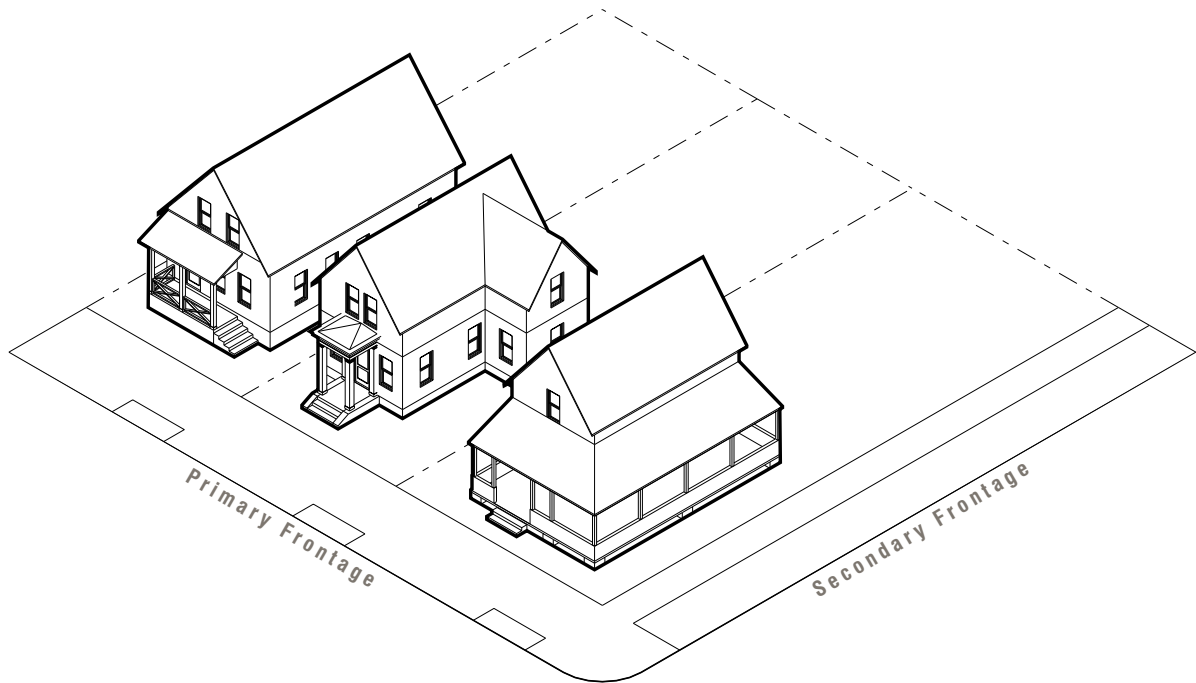

f. MASSING COMPONENTS

Rear Addition	●
Side Wing	●

g. ARCHITECTURAL COMPONENTS

Porch	●
Gallery	●
Stoop	●
Cross Gable	●
Shed Dormer	●
Dormer Window	●
Bay Window	●
Balcony	●
Portico	●
Canopy	●
Deck	●
Roof Deck	●

h. ROOFS

Gable Roof	●
Hipped Roof	●
Mansard Roof	●
Gambrel Roof	●

● Permitted

3. HOUSE

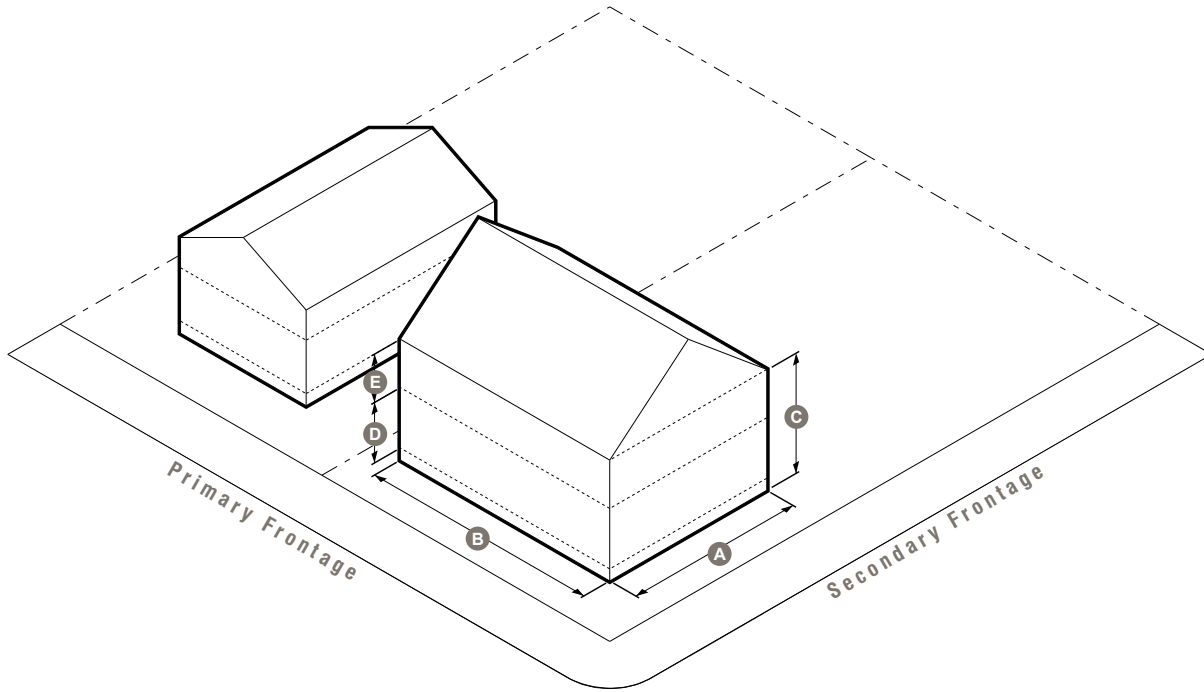

a. DESCRIPTION

A detached building with one unit.

b. BUILDING FORM

Building Width	21 ft min, 36 ft max	A
Building Length	48 ft max	B
Total Stories	2 stories max	C
First Floor Height	9 ft min, 12 ft max	D
Upper Floor Height	9 ft min, 10 ft max	E
First Floor Elevation	2 ft min	
Components	see Section D Components	
Roofs	see Section E Roof Types	
Attachments	none	

c. ALLOWABLE UNITS

1 unit max

d. FENESTRATION

First Floor Fenestration	20% min
Upper Floor Fenestration	20% min

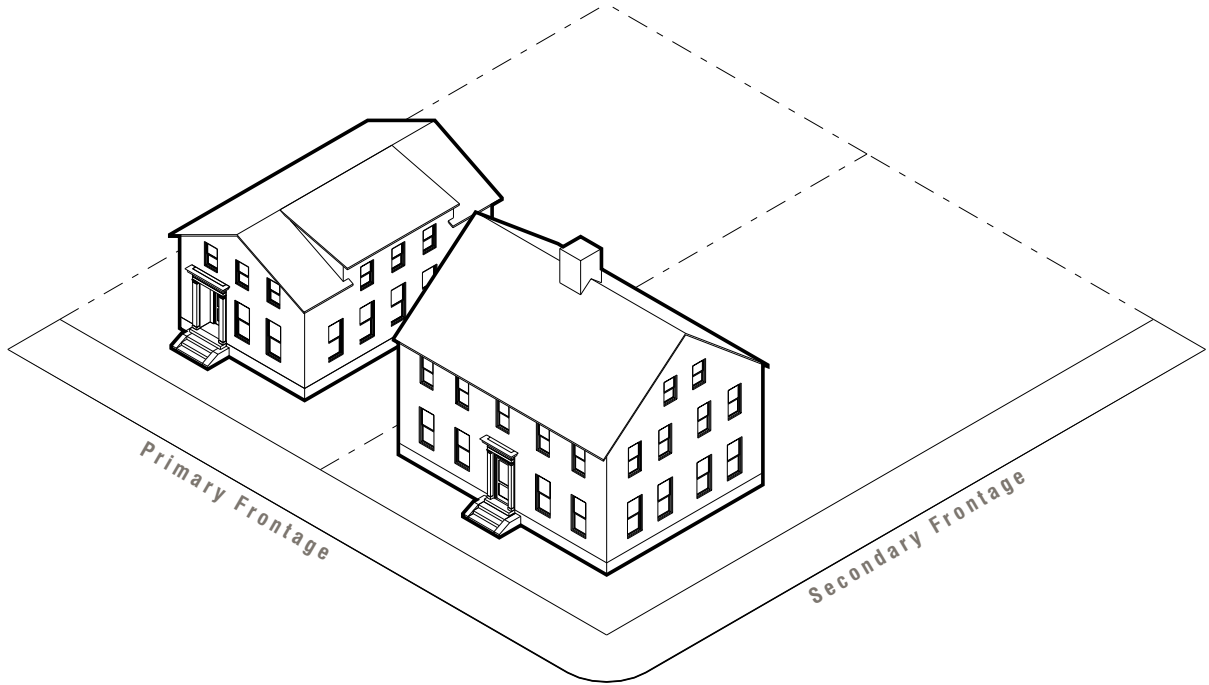

f. MASSING COMPONENTS

Rear Addition	●
Side Wing	●
Connector	●
Porte-Cochere	●
Tower	●

g. ARCHITECTURAL COMPONENTS

Porch	●
Gallery	●
Stoop	●
Cross Gable	●
Shed Dormer	●
Dormer Window	●
Bay Window	●
Balcony	●
Turret	●
Portico	●
Canopy	●
Deck	●
Roof Deck	●
Cupola	●

h. ROOFS

Gable Roof	●
Hipped Roof	●
Mansard Roof	●
Gambrel Roof	●

● Permitted

4. BUNGALOW

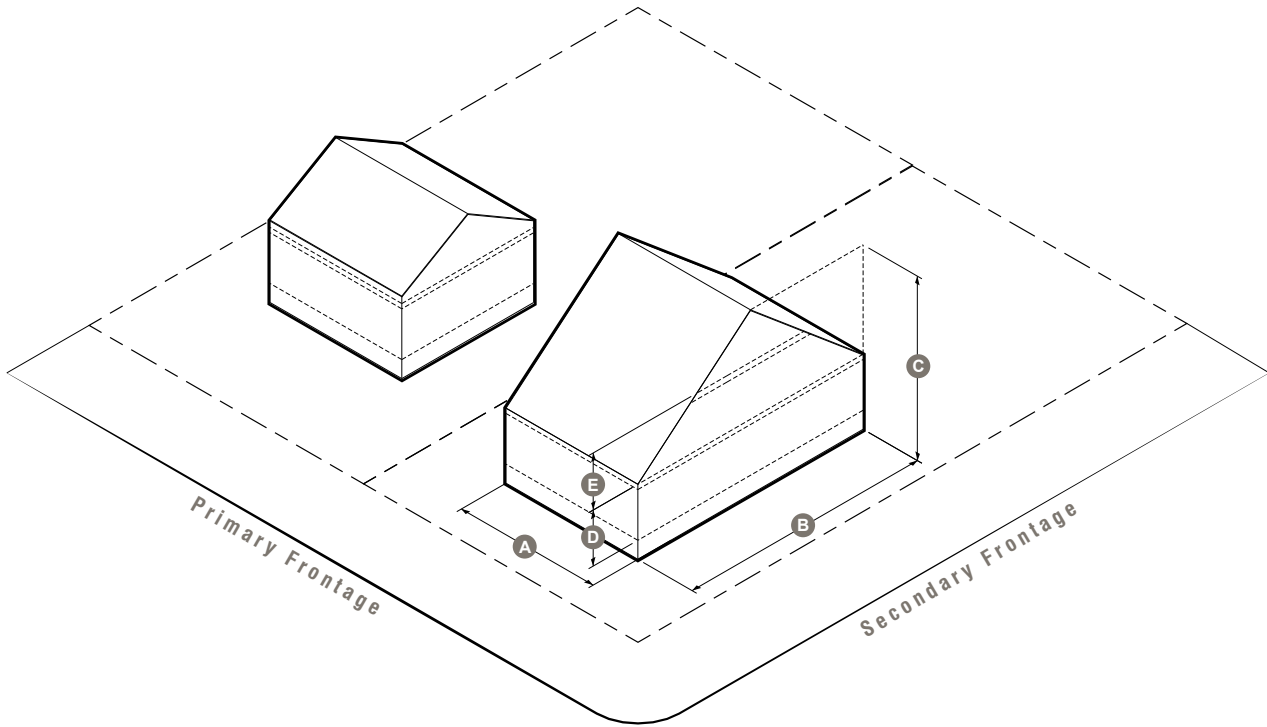

a. DESCRIPTION

A detached building with one unit and a front porch

b. BUILDING FORM

Building Width	36 ft max	A
Building Length	50 ft max	B
Total Stories	2 stories max (2)	C
First Floor Height	9 ft min, 12 ft max	D
Upper Floor Height	9 ft min, 10 ft max	E
First Floor Elevation	2 ft min	
Components	see Section D Components	
Roofs	see Section E Roof Types	
Attachments	none	

c. ALLOWABLE UNITS

1 unit max

d. WINDOWS & DOORS

First Floor Fenestration	20% min
Upper Floor Fenestration	20% min

e. STANDARDS

1. The gable end of a bungalow must be oriented away from the primary frontage.
2. Upper stories must be contained within the roof structure.

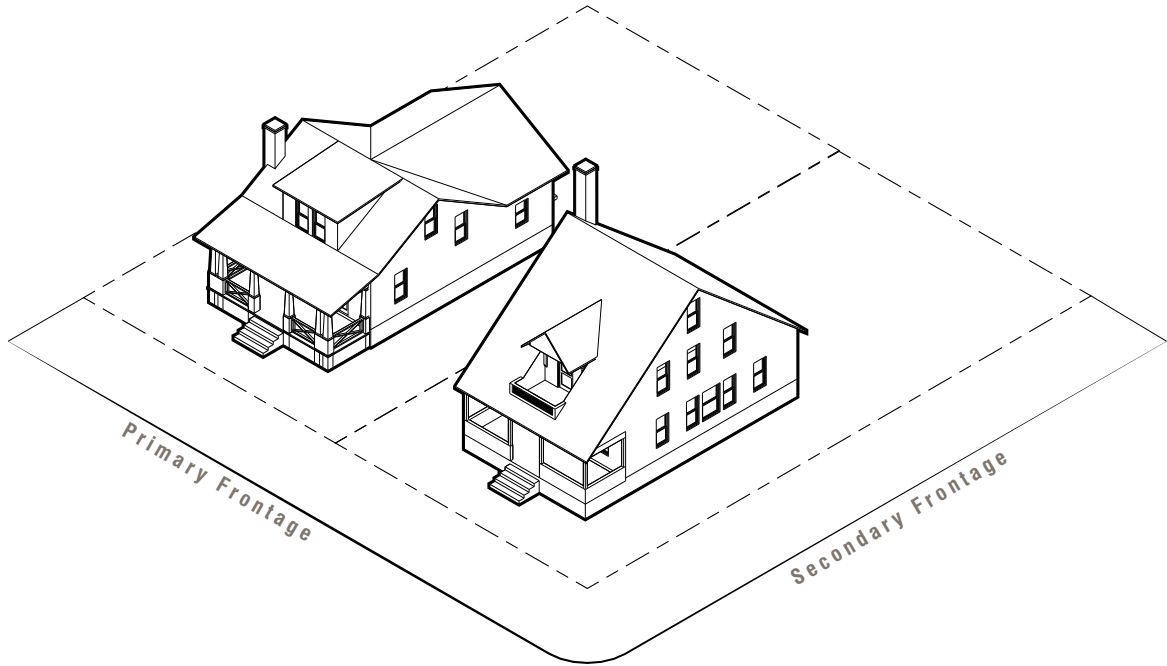

f. MASSING COMPONENTS

Rear Addition	●
Side Wing	●
Connector	●
Porte-Cochere	●

g. ARCHITECTURAL COMPONENTS

Porch	●
Gallery	●
Stoop	●
Cross Gable	●
Shed Dormer	●
Dormer Window	●
Bay Window	●
Balcony	●
Portico	●
Canopy	●
Deck	●
Roof Deck	●
Cupola	●

h. ROOFS

Gable Roof	●
Gambrel Roof	●

● Permitted

5. DUPLEX

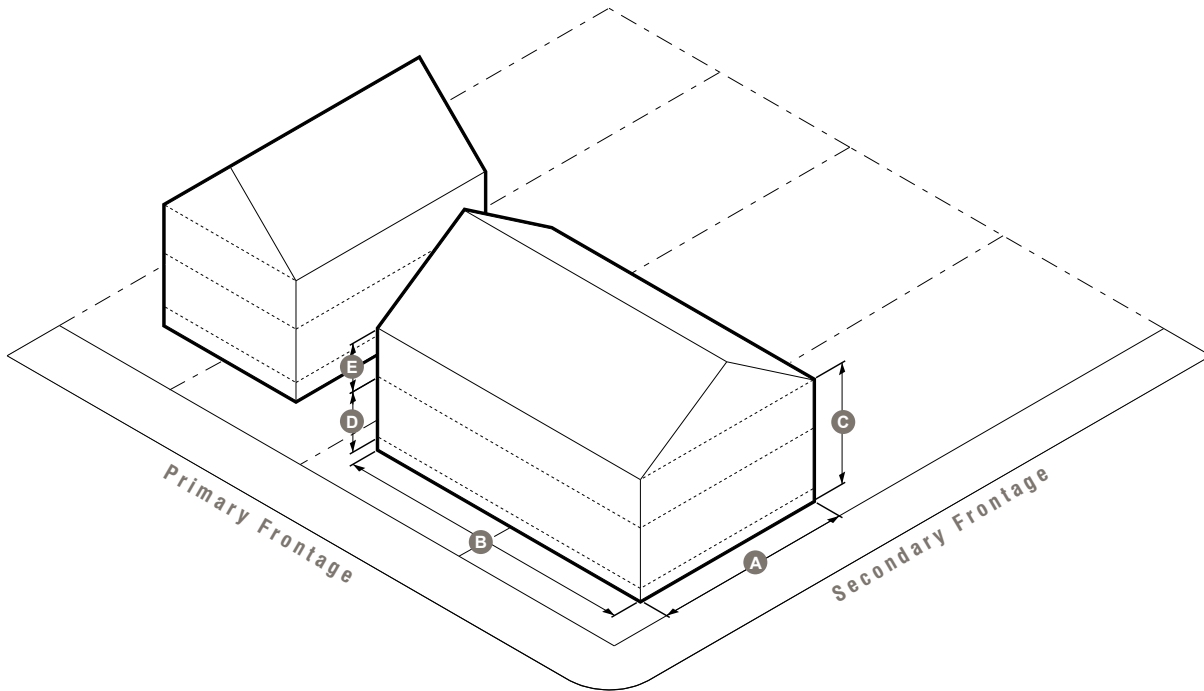

a. DESCRIPTION

A moderately scaled building type comprised of 2 units arranged side by side, where the building spans two lots, with one unit on each lot.

b. BUILDING FORM

Building Width	36 ft max	A
Building Length	48 ft max	B
Total Stories	3 max	C
First Floor Height	9 ft min, 12 ft max	D
Upper Floor Height	9 ft min, 12 ft max	E
First Floor Elevation	2 ft min	
Components	see Section D Components	
Roofs	see Section E Roof Types	
Attachments	none (3)	

c. ALLOWABLE UNITS

2 units max

d. FENESTRATION

First Floor Fenestration	20% min
Upper Floor Fenestration	20% min

e. STANDARDS

1. A porch or gallery may be built on the third floor of a primary frontage provided that there is only one porch or gallery below it on either the first or second floor.
2. A duplex may not attach to adjacent buildings.
3. The duplex is a single building that extends across a lot line. The internal shared wall does not count as an attachment.
4. A duplex may sit on a single lot provided the duplex is placed using theoretical lot lines showing how the lot can be divided in future, with one unit on each lot.

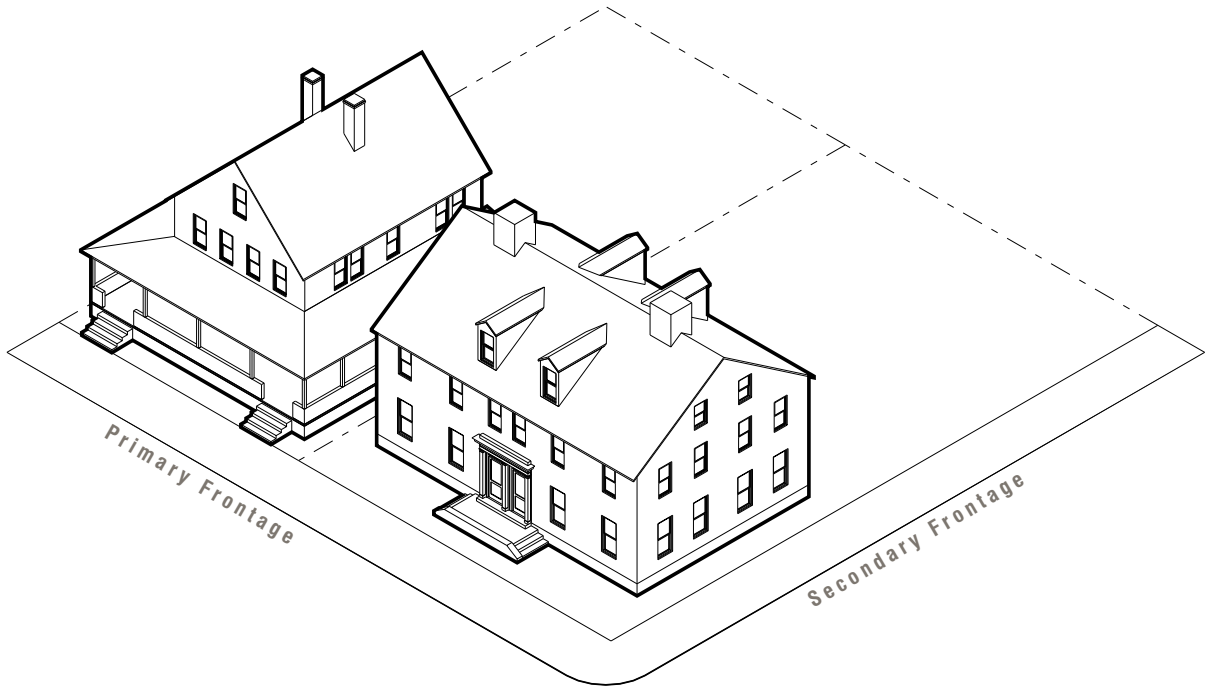

f. MASSING COMPONENTS

Rear Addition	●
Side Wing	●
Connector	●
Porte-Cochere	●
Tower	●

g. ARCHITECTURAL COMPONENTS

Porch	●
Gallery	●
Stoop	●
Cross Gable	●
Shed Dormer	●
Dormer Window	●
Bay Window	●
Balcony	●
Turret	●
Portico	●
Canopy	●
Deck	●
Roof Deck	●
Cupola	●

h. ROOFS

Gable Roof	●
Hipped Roof	●
Mansard Roof	●
Gambrel Roof	●

● Permitted

6. APARTMENT HOUSE

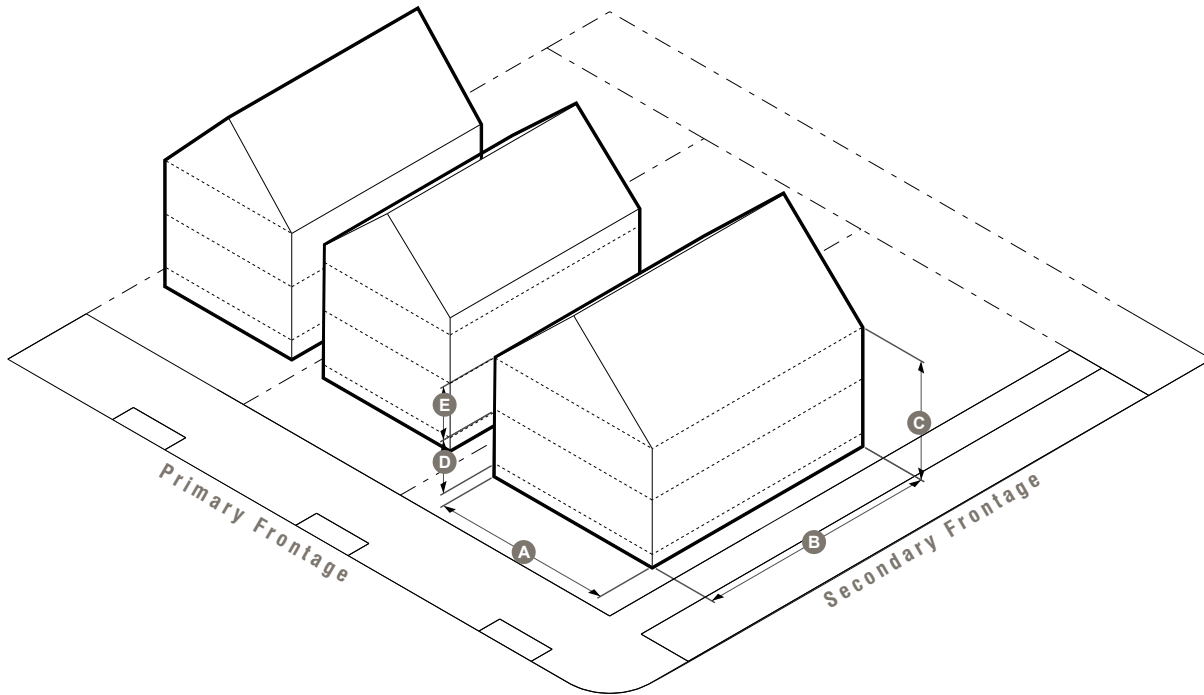

a. DESCRIPTION

A moderately scaled building type comprised of up to 5 units arranged side by side and/or stacked one above the other, yet occupying a single lot.

b. BUILDING FORM

Building Width	36 ft max	A
Building Length	75 ft max	B
Total Stories	3 max	C
First Floor Height	9 ft min, 12 ft max	D
Upper Floor Height	9 ft min, 12 ft max	E
First Floor Elevation	2 ft min	
Components	see Section D Components	
Roofs	see Section E Roof Types	
Attachments	none	

c. ALLOWABLE UNITS

5 units max

d. FENESTRATION

First Floor Fenestration	20% min
Upper Floor Windows & Doors	20% min

e. STANDARDS

1. A porch or gallery may be built on the third floor of a primary frontage provided that there is only one porch or galley below it on either the first or second floor.

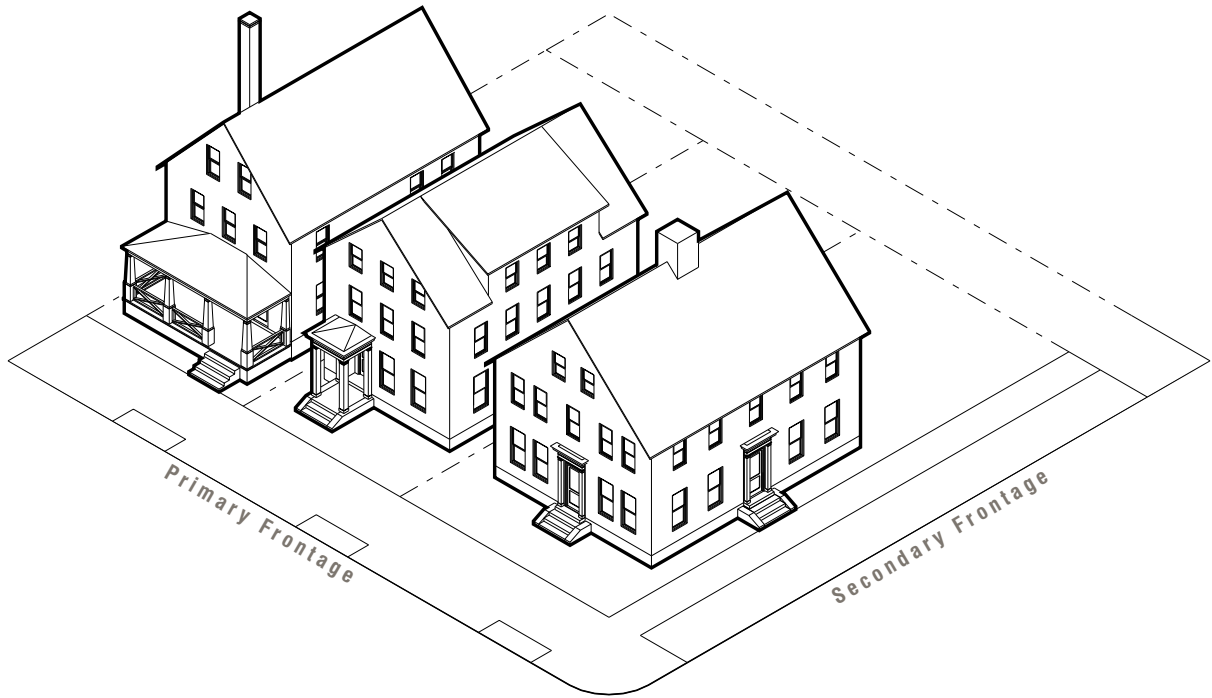

f. MASSING COMPONENTS

Rear Addition	●
Side Wing	●
Connector	●
Porte-Cochere	●
Tower	●

g. ARCHITECTURAL COMPONENTS

Porch	●
Gallery	●
Stoop	●
Cross Gable	●
Shed Dormer	●
Dormer Window	●
Bay Window	●
Balcony	●
Turret	●
Portico	●
Canopy	●
Deck	●
Roof Deck	●
Cupola	●

h. ROOFS

Gable Roof	●
Hipped Roof	●
Mansard Roof	●
Gambrel Roof	●

● Permitted

7. APARTMENT BUILDING

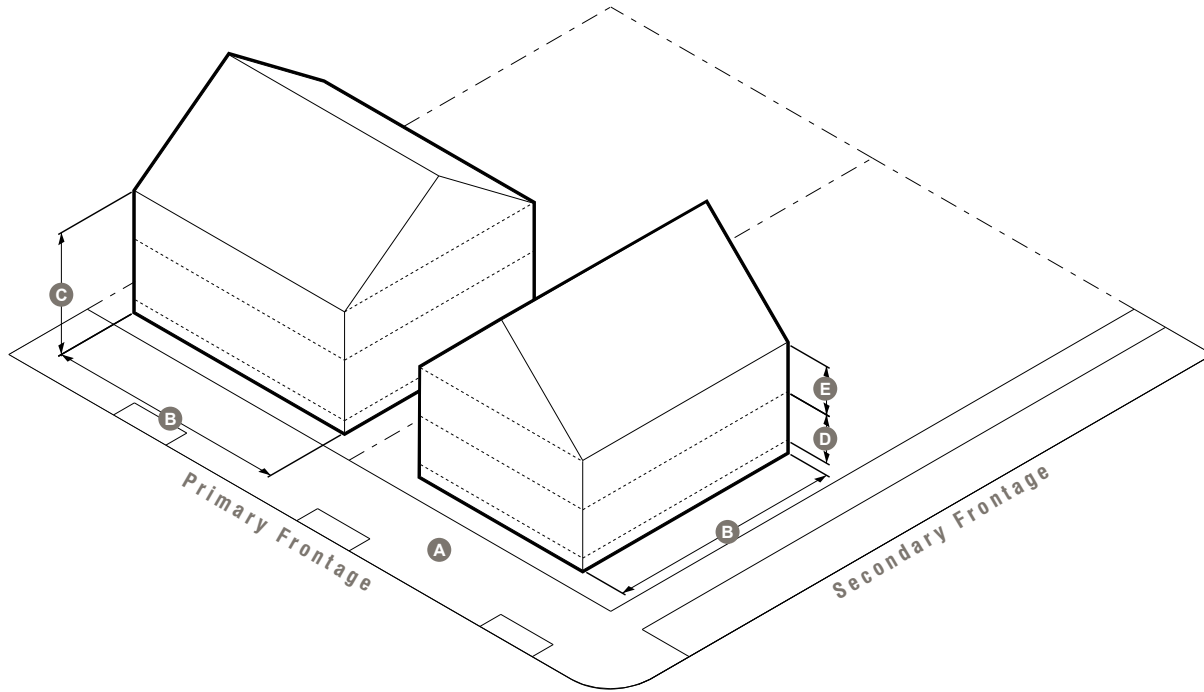

a. DESCRIPTION

A moderately scaled building type comprised of up to 12 units.

b. BUILDING FORM

Building Width	60 ft max	A
Building Length	75 ft max	B
Total Stories	3 stories max	C
First Floor Height	9 ft min, 15 ft max	D
Upper Floor Height	9 ft min, 12 ft max	E
First Floor Elevation	2 ft min	
Components	see D Components	
Roofs	see E Roof Types	
Attachments	none	

c. ALLOWABLE UNITS

12 units max

d. FENESTRATION

First Floor Fenestration	20% min
Upper Floor Fenestration	20% min

e. STANDARDS

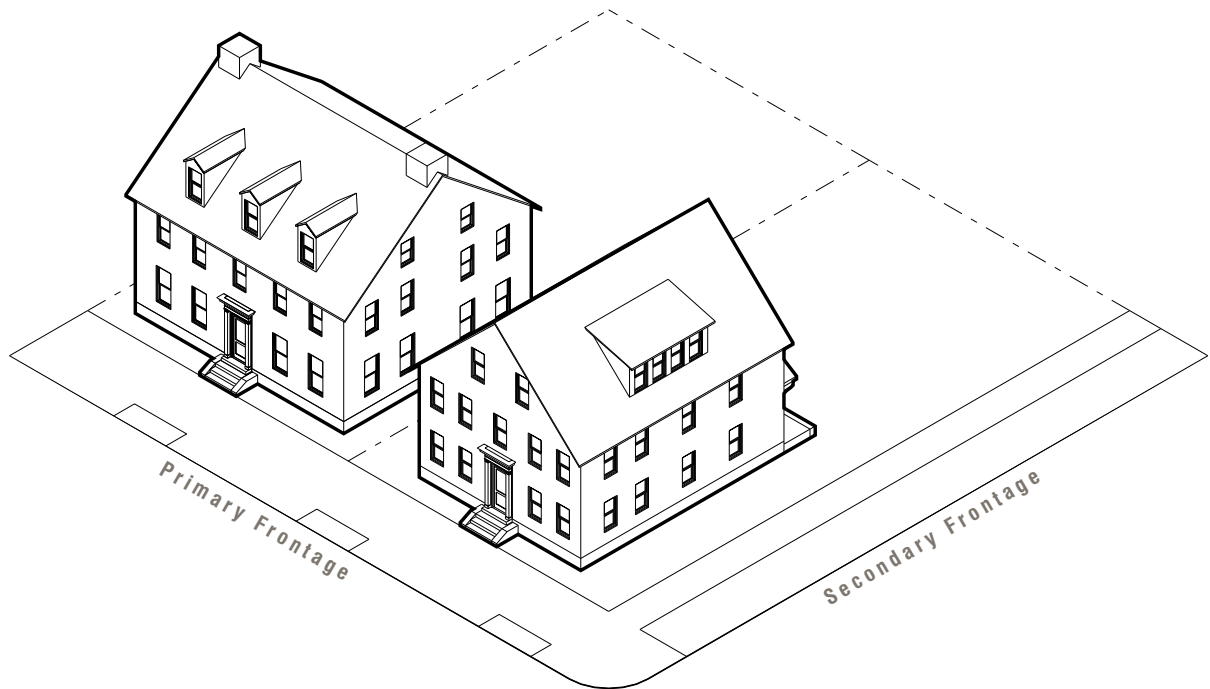

f. MASSING COMPONENTS

Rear Addition	●
Side Wing	●
Connector	●
Porte-Cochere	●
Tower	●

g. ARCHITECTURAL COMPONENTS

Porch	●
Gallery	●
Stoop	●
Cross Gable	●
Shed Dormer	●
Dormer Window	●
Bay Window	●
Balcony	●
Turret	●
Portico	●
Canopy	●
Deck	●
Roof Deck	●
Cupola	●

h. ROOFS

Gable Roof	●
Hipped Roof	●
Mansard Roof	●
Gambrel Roof	●

● Permitted

8. TOWNHOUSE

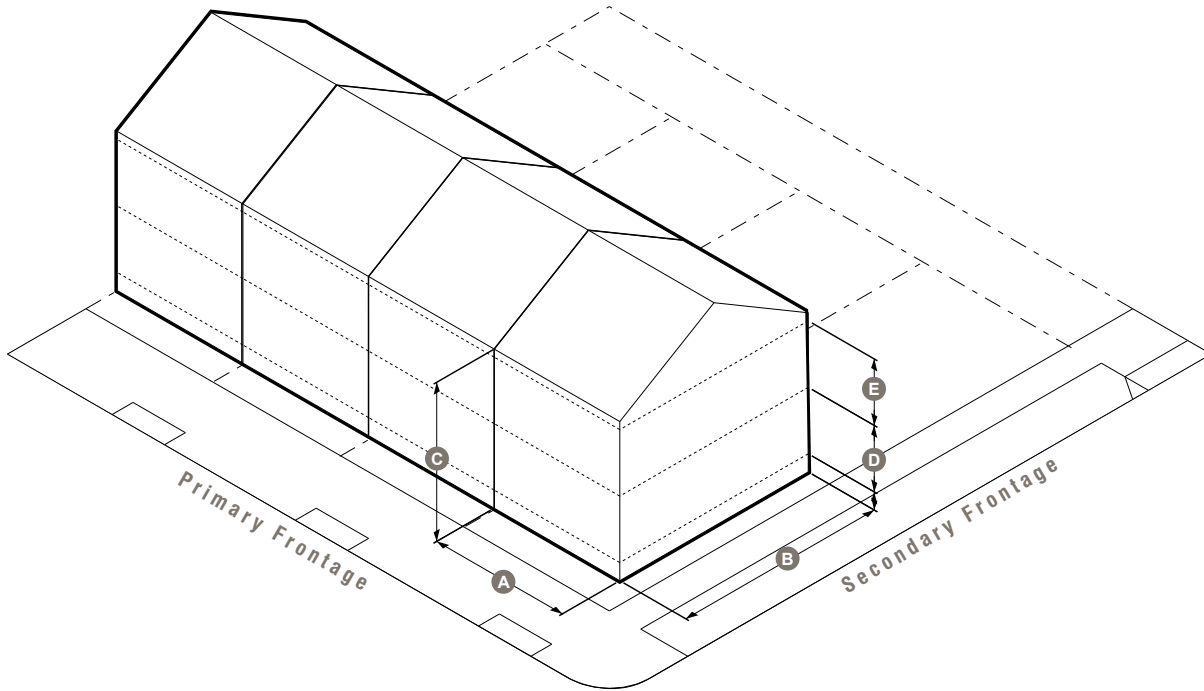

a. DESCRIPTION

A small- to medium-sized attached building type comprised of up to 3 units.

b. BUILDING FORM

Building Width	18 ft min, 36 ft max	A
Building Length	50 ft max	B
Total Stories	2 min, 3 max	C
First Floor Height	9 ft min, 12 ft max	D
Upper Floor Height	9 ft min, 12 ft max	E
First Floor Elevation	2 ft min	
Components	see Section D Components	
Roofs	see Section E Roof Types	
Attachments	1 side min	

c. ALLOWABLE UNITS

3 unit max

d. FENESTRATION

First Floor Fenestration	20% min
Upper Floor Fenestration	20% min

e. STANDARDS

1. A townhouse must attach to a townhouse or live/work flex on at least one side.
2. A maximum of 6 townhouses are allowed to attach.
3. All buildings in a single grouping of attached townhouses must maintain the same front setback.

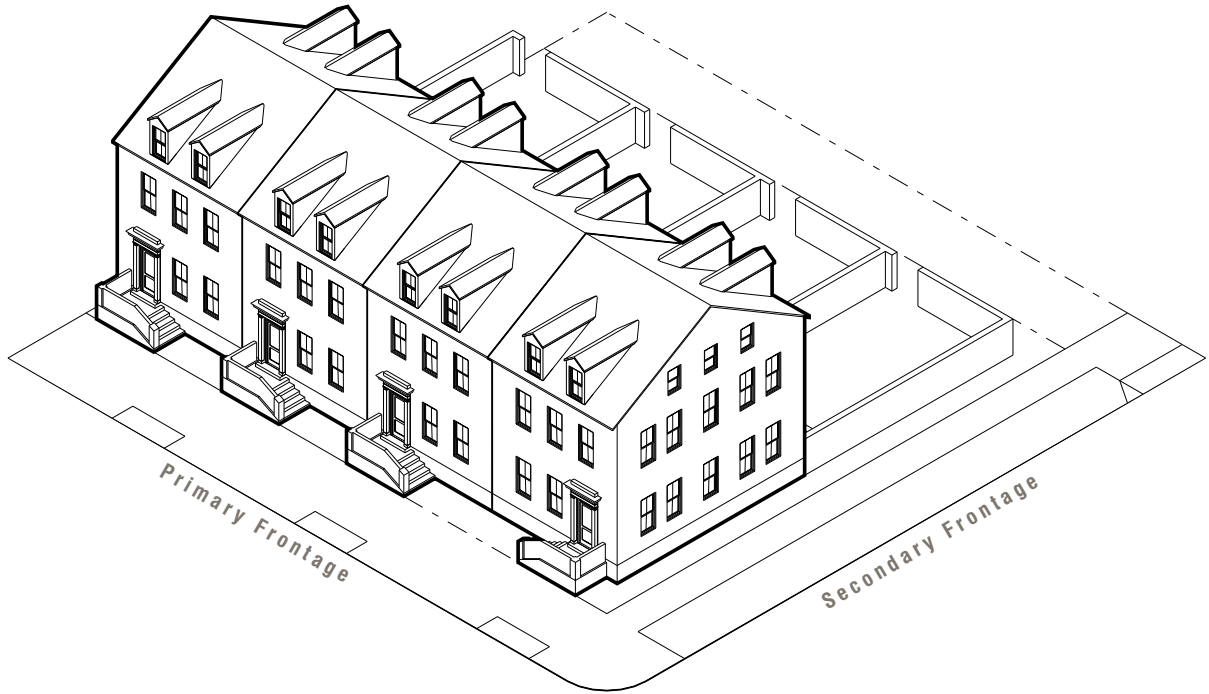

f. MASSING COMPONENTS

Rear Addition	●
Side Wing	●
Connector	●
Porte-Cochere	●

g. ARCHITECTURAL COMPONENTS

Porch	●
Gallery	●
Stoop	●
Cross Gable	●
Shed Dormer	●
Dormer Window	●
Bay Window	●
Balcony	●
Turret	●
Portico	●
Canopy	●
Deck	●
Roof Deck	●

h. ROOFS

Gable Roof	●
Hipped Roof	●
Shed Roof	●
Flat Roof	●

● Permitted

9. SHOPHOUSE

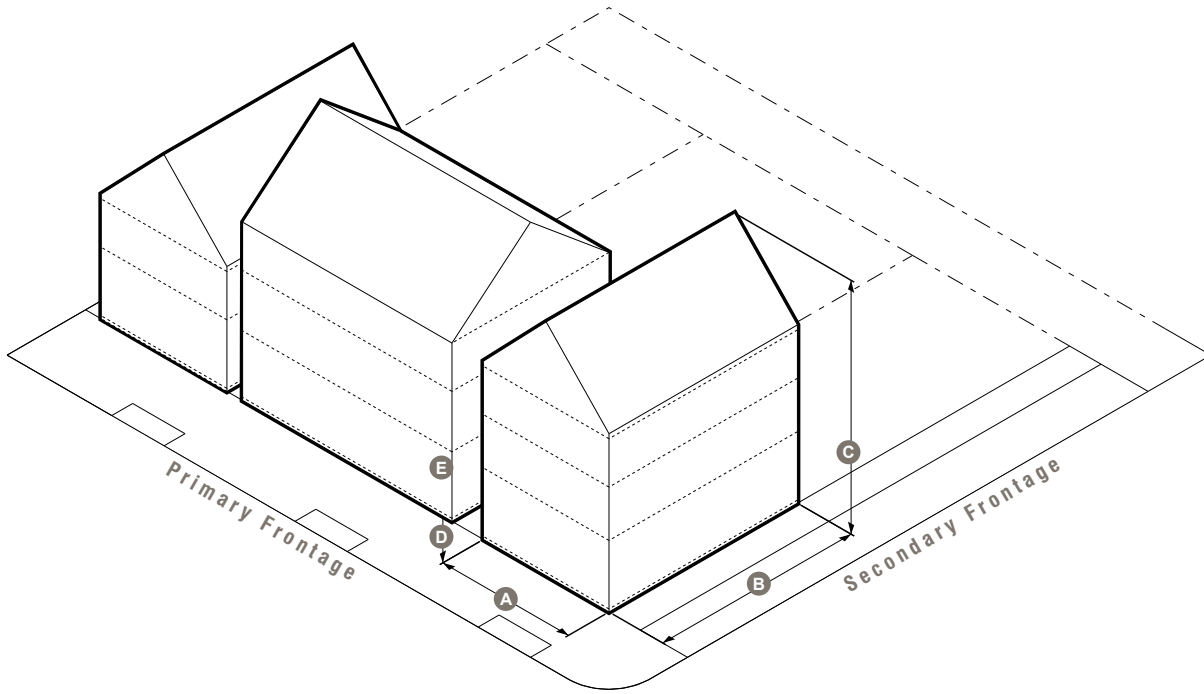

a. DESCRIPTION

A small building with a shopfront and up to 5 units.

b. BUILDING FORM

Building Width	36 ft max	A
Building Length	60 ft max	B
Total Stories	3 max	C
First Floor Height	12 ft min, 18 ft max	D
Upper Floor Height	9 ft min, 12 ft max	E
First Floor Elevation	0 ft min	
Components	see Section D Components	
Roof	see Section E Roof Types	
Attachments	1 side max	

c. ALLOWABLE UNITS

5 units max

d. FENESTRATION

Shopfront	Required
First Floor Fenestration	20% min
Upper Floor Fenestration	20% min

e. STANDARDS

1. Shopfront fenestration is required on the first floor facade of the primary frontage.
2. A porch or gallery may be built on the third floor of a primary frontage provided that there is only one porch or galley below it on either the first or second floor.

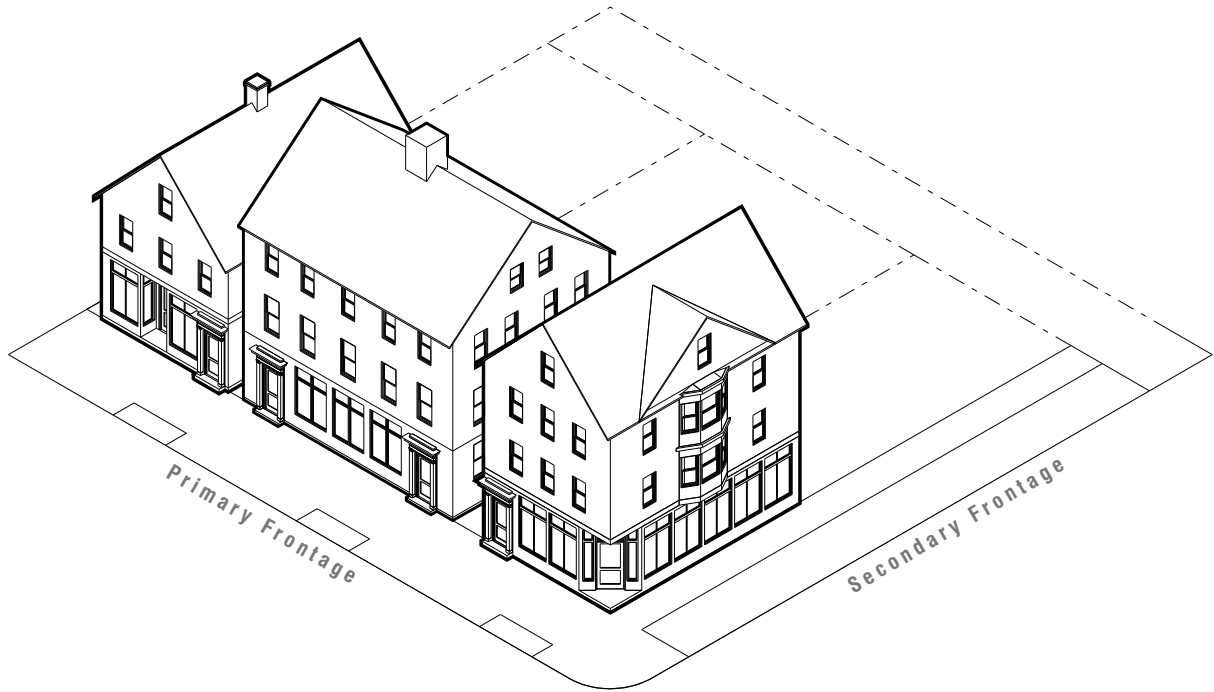

f. MASSING COMPONENTS

Rear Addition	●
Side Wing	●
Connector	●
Tower	●

g. ARCHITECTURAL COMPONENTS

Porch	●
Gallery	●
Stoop	●
Cross Gable	●
Shed Dormer	●
Dormer Window	●
Bay Window	●
Balcony	●
Turret	●
Arcade	●
Portico	●
Canopy	●
Deck	●
Roof Deck	●
Cupola	●

h. ROOFS

Gable Roof	●
Hipped Roof	●
Mansard Roof	●
Gambrel Roof	●

● Permitted

10. LIVE/WORK FLEX

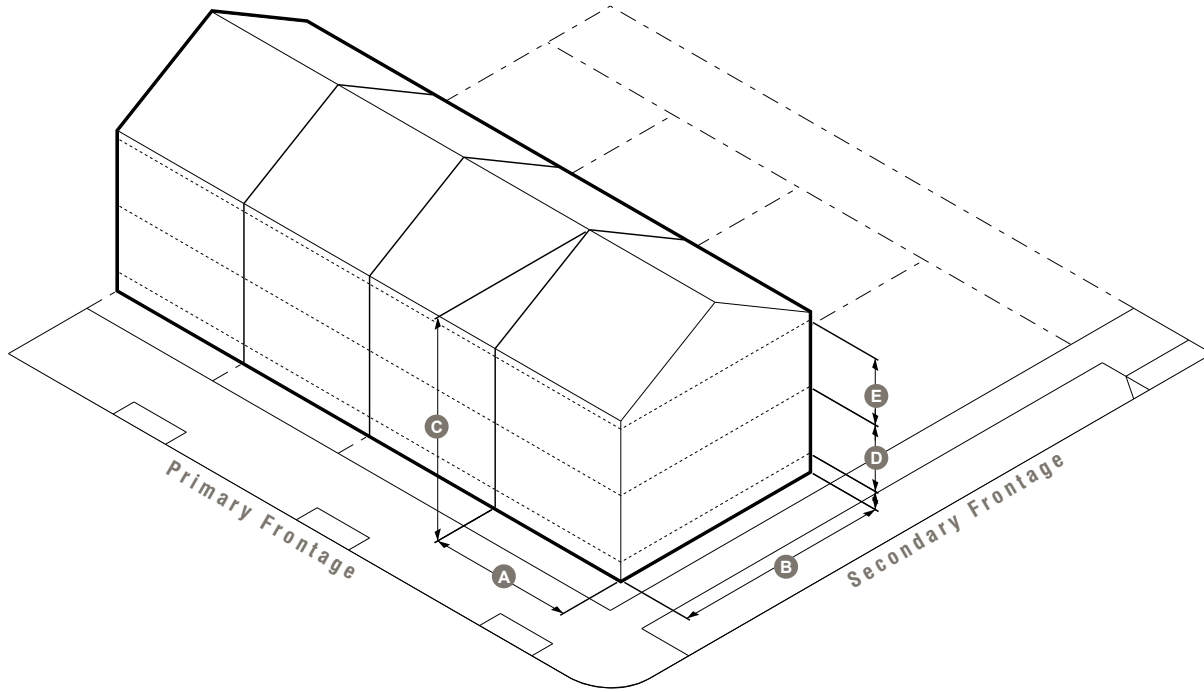

a. DESCRIPTION

A small attached building type with up to 3 units, including an optional shopfront.

b. BUILDING FORM

Building Width	18 ft min, 60 ft max	A
Building Length	60 ft max	B
Total Stories	2 min, 3 max	C
First Floor Height	9 ft min, 14 ft max	D
Upper Floor Height	9 ft min, 12 ft max	E
First Floor Elevation	0 ft min	
Components	see Section D Components	
Roofs	see Section E Roof Types	
Attachments	1 side min	

c. ALLOWABLE UNITS

3 units max

d. FENESTRATION

Shopfront	Optional
First Floor Fenestration	20% min
Upper Floor Fenestration	20% min

e. STANDARDS

1. A live/work flex building must attach to a townhouse or live/work flex on at least one side.
2. A maximum of 6 live/work flex buildings are allowed to attach.
3. All buildings in a single grouping of attached live/work flex buildings must maintain the same front setback.

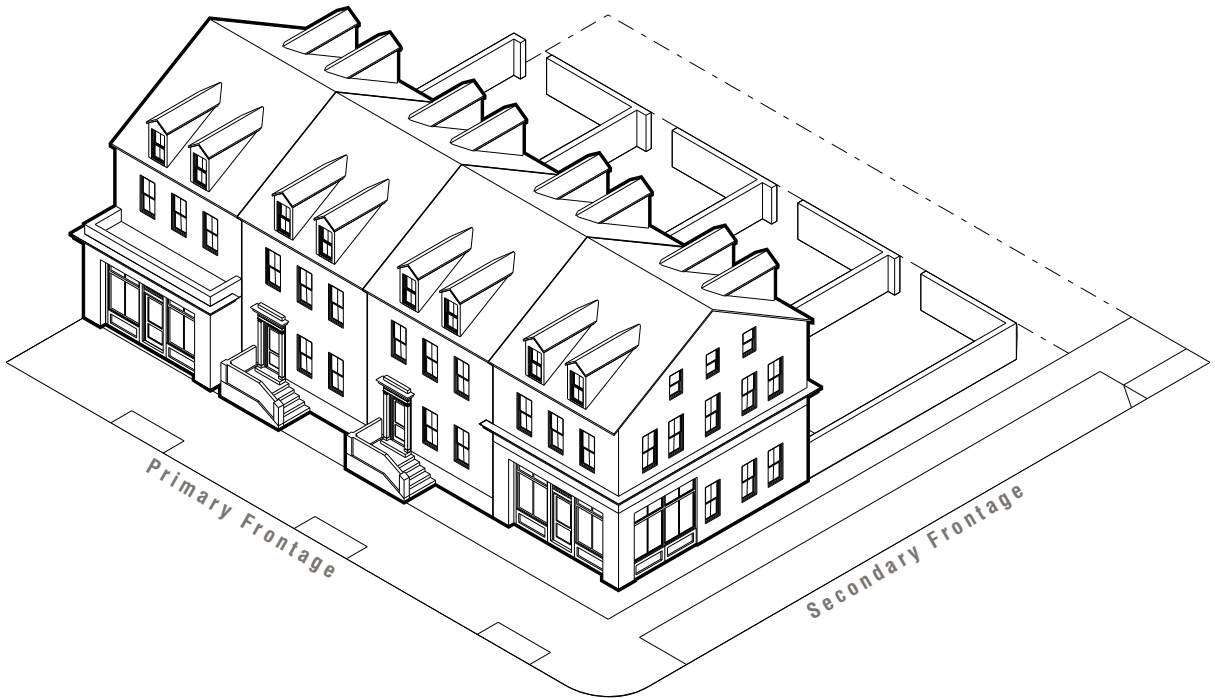

f. MASSING COMPONENTS

Rear Addition	●
Side Wing	●
Connector	●
Extended Shopfront	●

g. ARCHITECTURAL COMPONENTS

Porch	●
Gallery	●
Stoop	●
Cross Gable	●
Shed Dormer	●
Dormer Window	●
Bay Window	●
Balcony	●
Turret	●
Portico	●
Canopy	●
Deck	●
Roof Deck	●

h. ROOFS

Gable Roof	●
Hipped Roof	●
Shed Roof	●
Flat Roof	●

● Permitted

11. SHOP

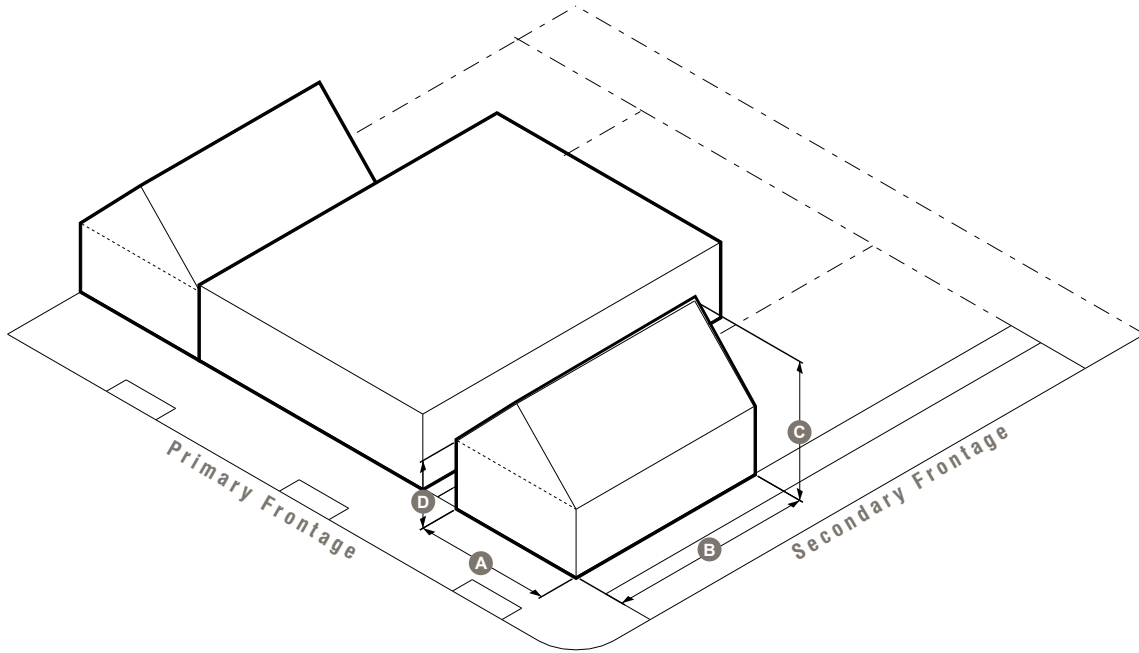

a. DESCRIPTION

A single story building with 1 unit and a required shopfront.

b. BUILDING FORM

Building Width	18 ft min, 90 ft max	A
Building Length	60 ft max	B
Total Stories	1 max	C
First Floor Height	20 ft max	D
Upper Floor Height	n/a	E
First Floor Elevation	0 ft min	
Components	see Section D Components	
Roofs	see Section E Roof Types	
Attachments	1 side max	

c. ALLOWABLE UNITS

1 unit max

d. FENESTRATION

Shopfront	Required
First Floor Fenestration	20% min
Upper Floor Fenestration	n/a

e. STANDARDS

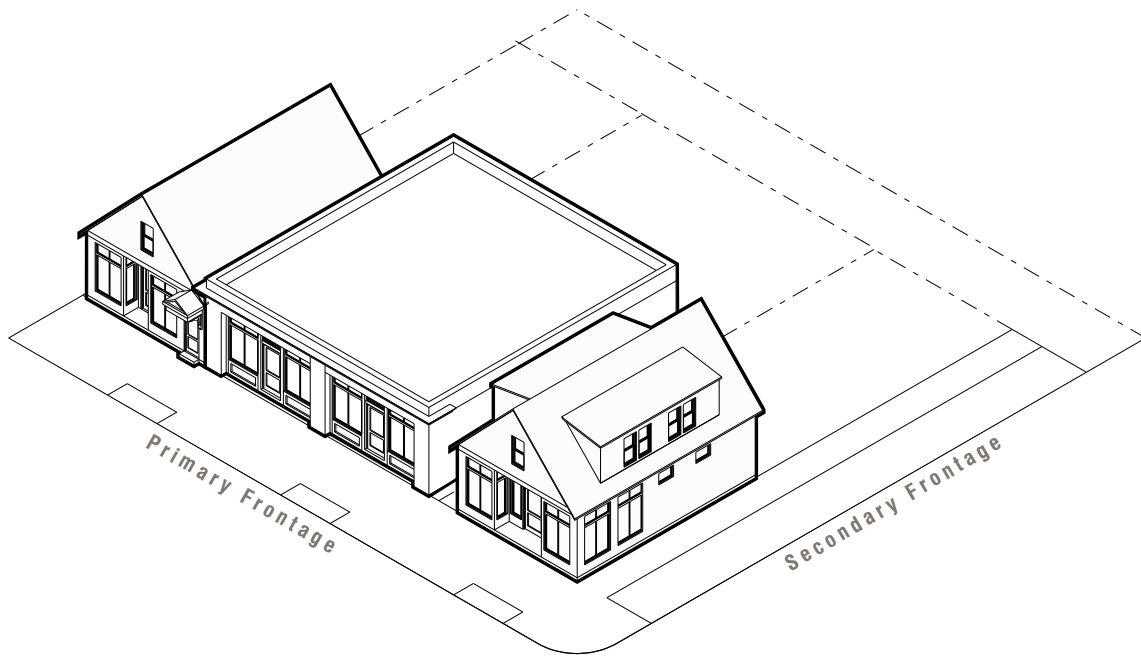

f. MASSING COMPONENTS

Rear Addition	●
Side Wing	●

g. ARCHITECTURAL COMPONENTS

Porch	●
Stoop	●
Cross Gable	●
Shed Dormer	●
Dormer Window	●
Bay Window	●
Arcade	●
Portico	●
Canopy	●
Deck	●
Roof Deck	●
Cupola	●

h. ROOFS

Gable Roof	●
Hipped Roof	●
Gambrel Roof	●
Shed Roof	●
Flat Roof	●

● Permitted

12. INN

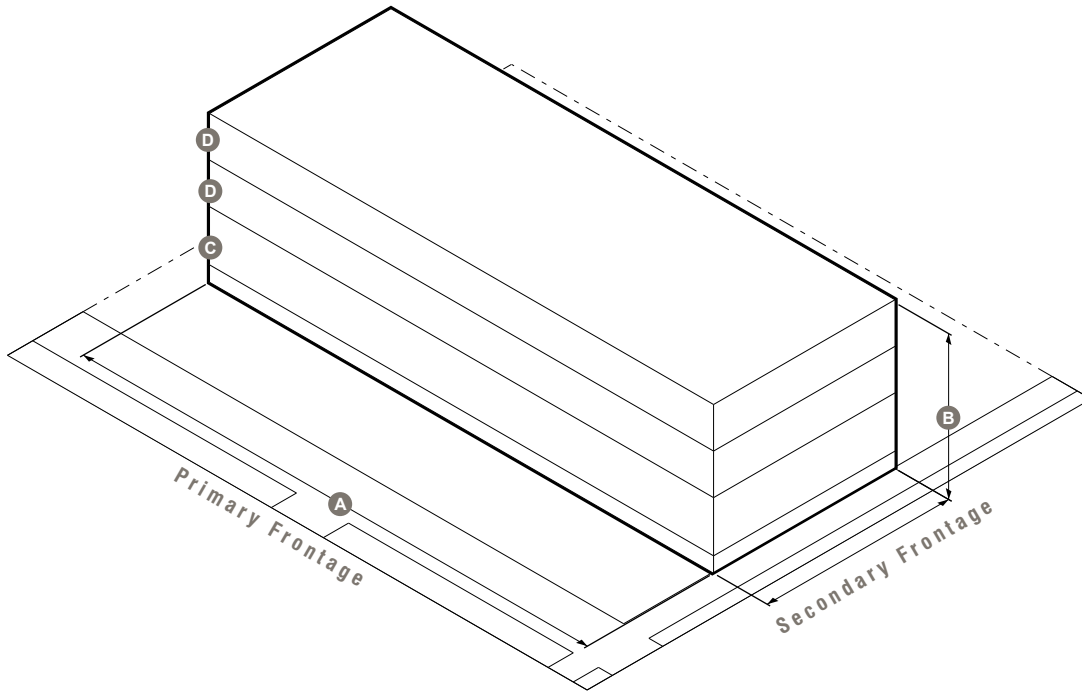

a. DESCRIPTION

A large building providing multiple units, common area living, dining and cooking facilities, and that has a continuous front porch.

b. BUILDING FORM

Building Length	120 ft max	(A)
Total Building Area	20,000 sf max	
Total Stories	3 max	(B)
First Floor Height	10 ft min, 15 ft max	(C)
Upper Floor Height	9 ft min, 12 ft max	(D)
First Floor Elevation	2 ft min	
Components	see Section D Components	
Roofs	see Section E Roof Types	
Attachments	none	

c. ALLOWABLE UNITS

varies

d. FENESTRATION

First Floor Fenestration	20% min
Upper Floor Fenestration	20% min

e. STANDARDS

1. The inn building floor plate may not exceed 15,000 sf.
2. The inn building may front a primary street provided the front porch is continuous along the frontage and is not enclosed.

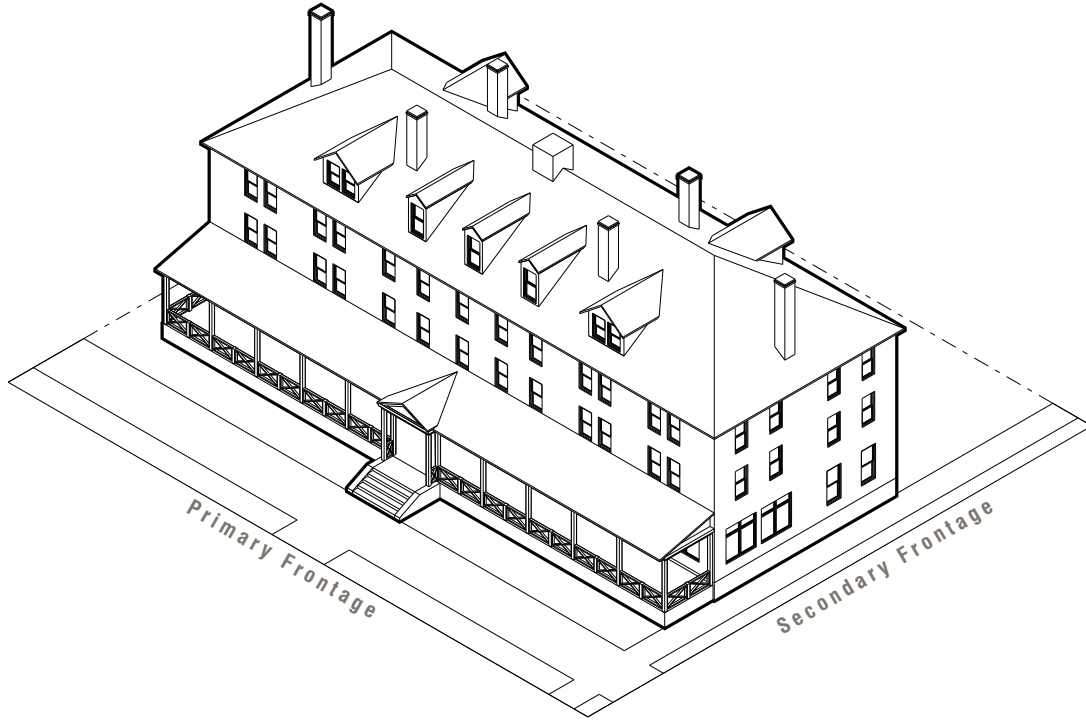

f. MASSING COMPONENTS

Rear Addition	●
Side Wing	●
Connector	●
Extended Shopfront	●
Porte-Cochere	●
Tower	●

g. ARCHITECTURAL COMPONENTS

Porch	●
Gallery	●
Stoop	●
Cross Gable	●
Shed Dormer	●
Dormer Window	●
Bay Window	●
Balcony	●
Turret	●
Arcade	●
Portico	●
Canopy	●

Deck	●
Roof Deck	●
Cupola	●

h. ROOFS

Gable Roof	●
Hipped Roof	●
Mansard Roof	●
Gambrel Roof	●
Flat Roof	●

● Permitted

13. FABRICATION BUILDING

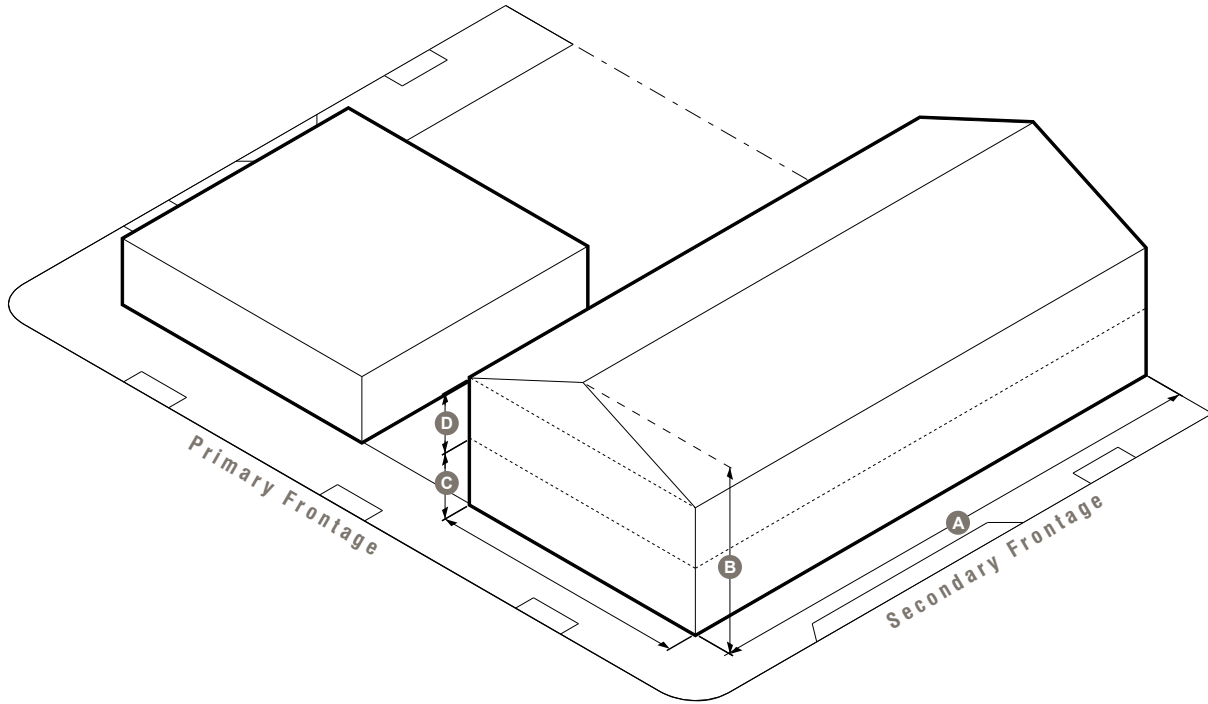

a. DESCRIPTION

A large floor plate, building type with large open floor plans, and optional shopfronts, providing multiple units.

b. BUILDING FORM

Building Length	150 ft max	A
Building Area	30,000 sf max	
Total Stories	2 max	B
First Floor Height	9 ft min	C
Upper Floor Height	9 ft min	D
First Floor Elevation	0 ft min	
Components	see Section D Components	
Roofs	see Section E Roof Types	
Attachments	2 sides max	

c. ALLOWABLE UNITS

1 unit min

d. FENESTRATION

Shopfront	Optional
First Floor Fenestration	30%
Upper Floor Fenestration	30%

e. STANDARDS

1. Fabrication buildings must be oriented perpendicular to the primary thoroughfare (excluding alleys).
2. The fabrication building floor plate may not exceed 15,000 sf.
3. Shed dormers may ignore the gable end and ridge line setback in order to form a continuous monitor style roof along the entirety of the ridge beam.

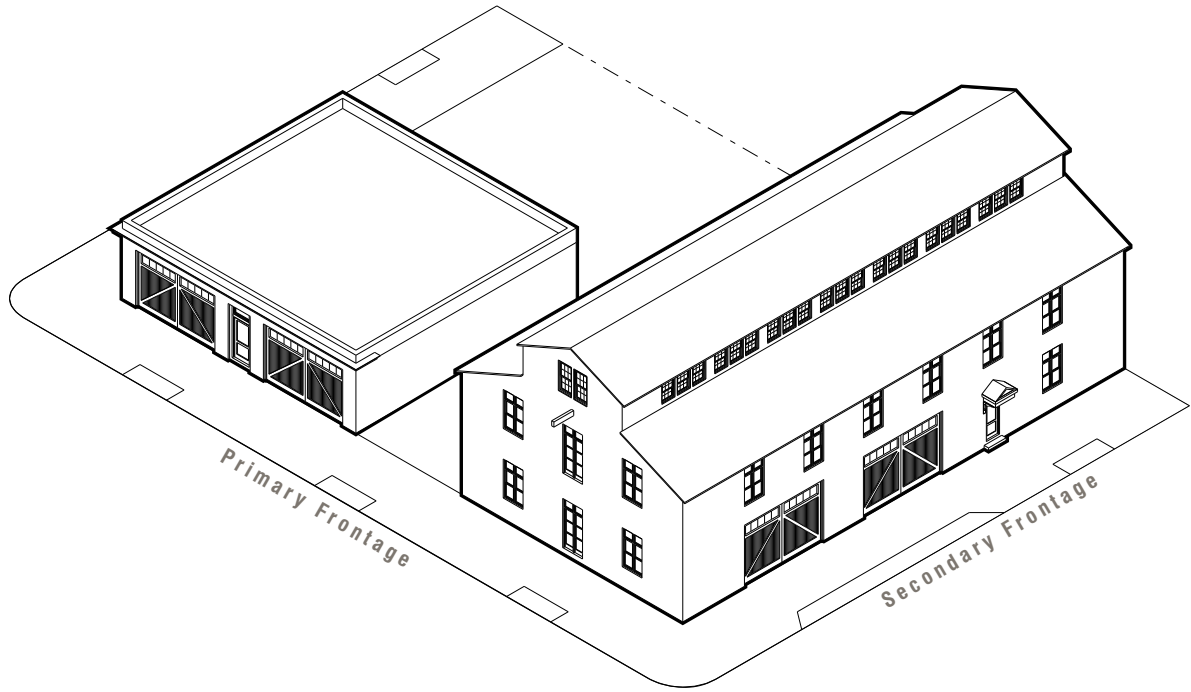

f. MASSING COMPONENTS

Rear Addition	●
Side Wing	●
Connector	●
Extended Shopfront	●
Porte-Cochere	●
Tower	●

g. ARCHITECTURAL COMPONENTS

Porch	●
Gallery	●
Stoop	●
Cross Gable	●
Shed Dormer	●
Dormer Window	●
Bay Window	●
Balcony	●
Arcade	●
Portico	●
Canopy	●
Deck	●
Cupola	●

h. ROOFS

Gable Roof	●
Hipped Roof	●
Gambrel Roof	●
Shed Roof	●
Flat Roof	●

● Permitted

14. MIXED-USE BUILDING

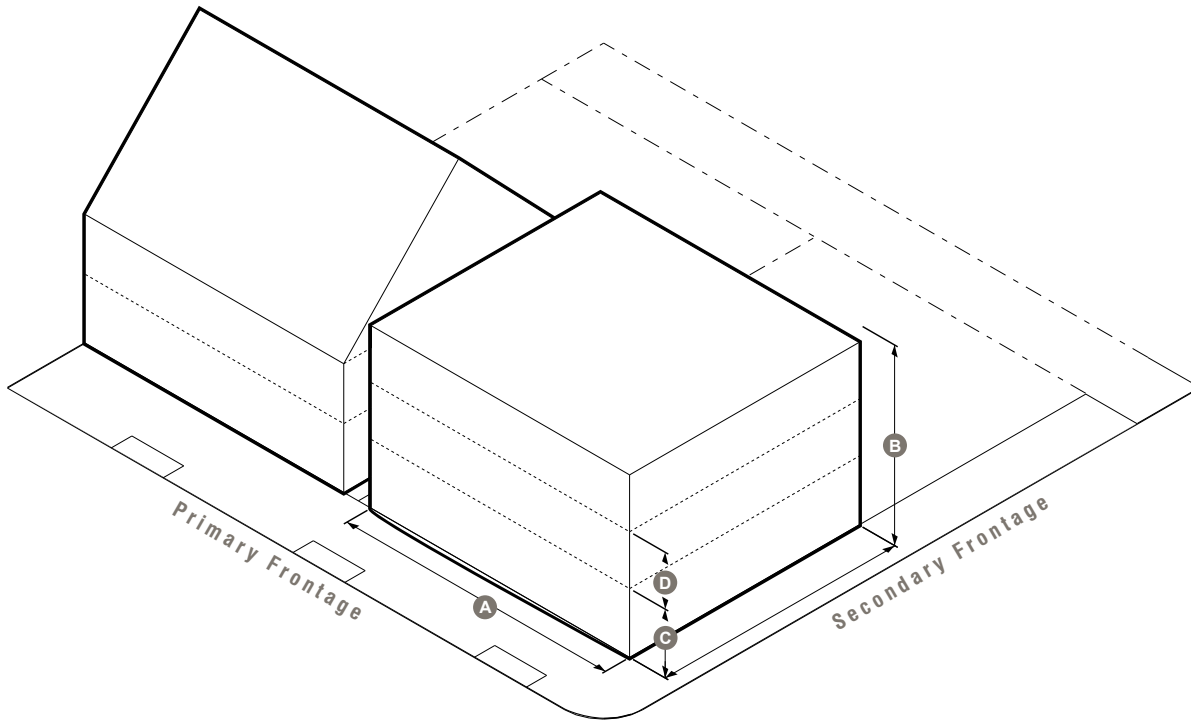

a. DESCRIPTION

A variably-sized building type with a required shopfront providing multiple units.

b. BUILDING FORM

Frontage Length	100 ft max	A
Ground Floor Plate Area	10,000 sf max	
Upper Floor Plate Area	10,000 sf max	
Total Stories	3 max	B
First Floor Height	12 ft min, 20 ft max	C
Upper Floor Height	9 ft min, 12 ft max	D
First Floor Elevation	0 ft max	
Components	see Section D Components	
Roofs	see Section E Roof Types	
Attachments	2 sides max	

c. ALLOWABLE UNITS

Units per floor	10 units max
-----------------	--------------

d. FENESTRATION

Shopfront	Required
First Floor Fenestration	70% min
Upper Floor Fenestration	20% min

e. STANDARDS

- Shopfronts are required on the first floor of the primary frontage.

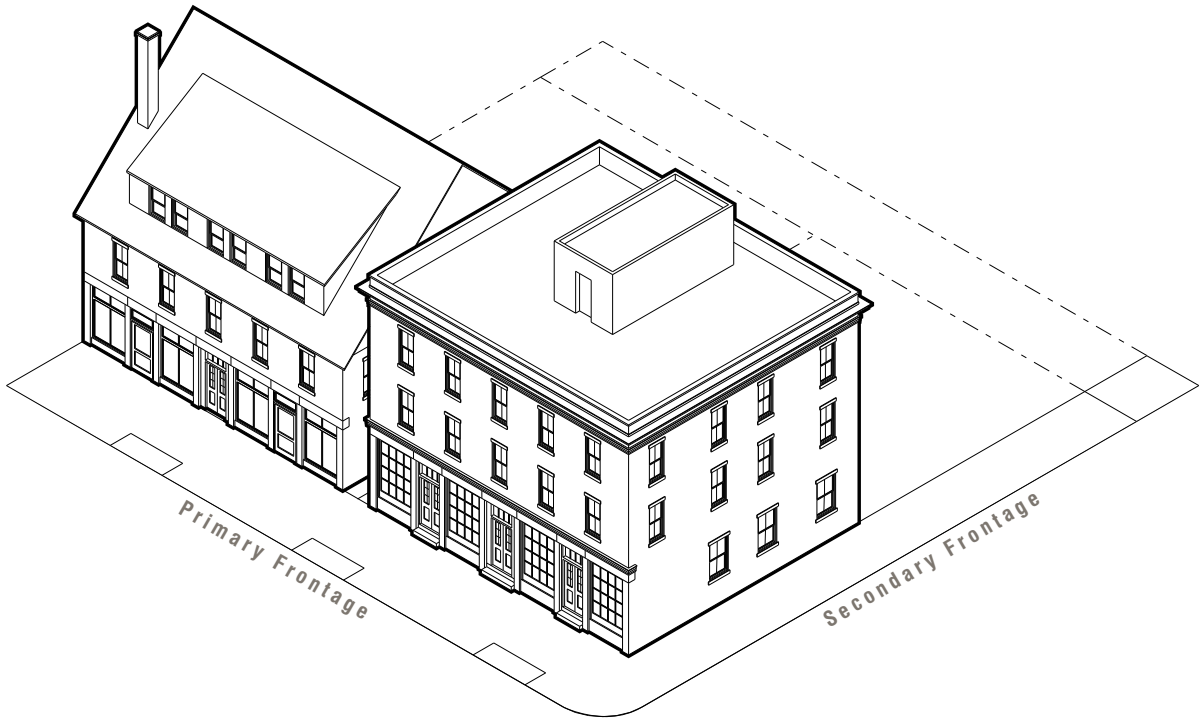

f. MASSING COMPONENTS

Rear Addition	●
Side Wing	●
Connector	●
Extended Shopfront	●

g. ARCHITECTURAL COMPONENTS

Porch	●
Gallery	●
Stoop	●
Cross Gable	●
Shed Dormer	●
Dormer Window	●
Bay Window	●
Balcony	●
Turret	●
Arcade	●
Portico	●
Canopy	●
Deck	●
Roof Deck	●
Cupola	●

h. ROOFS

Gable Roof	●
Hipped Roof	●
Mansard Roof	●
Gambrel Roof	●
Shed Roof	●
Flat Roof	●

● Permitted

15. CIVIC BUILDING

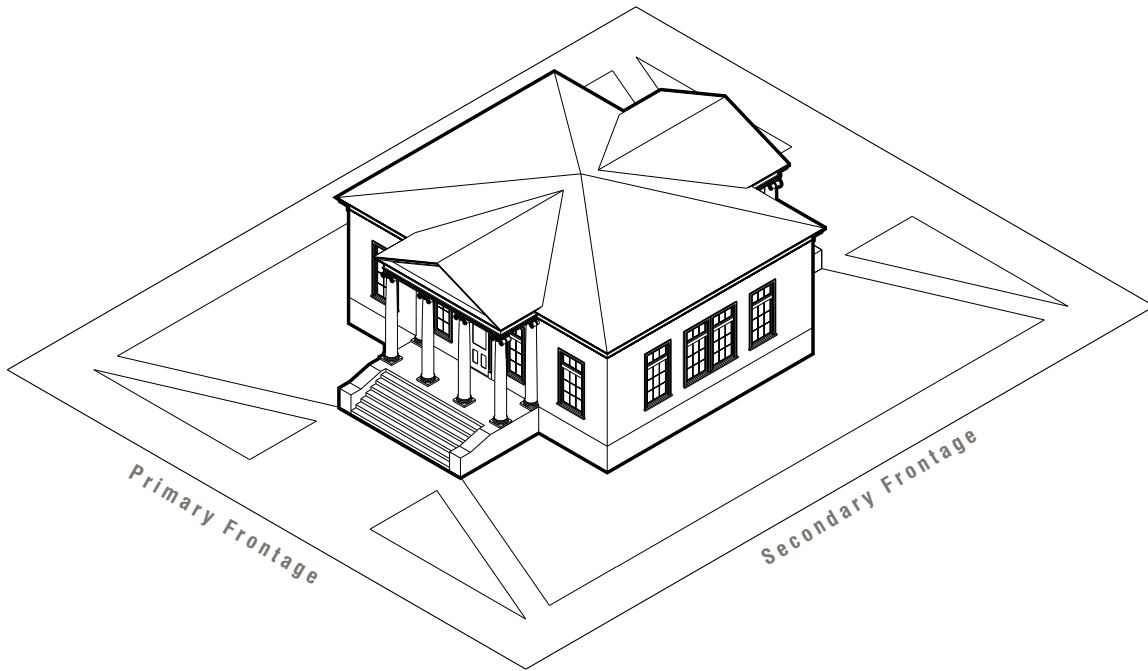

a. DESCRIPTION

A public building of high design and construction quality, usually a landmark.

b. BUILDING FORM

Building Length	100 ft max
Building Area	50,000 sf max
Total Stories	3 max
First Floor Height	15 ft min
Upper Floor Height	12 ft min
First Floor Elevation	0 ft min
Components	see Section Components
Roofs	see Section Roof Types (3)
Attachments	2 sides max

c. ALLOWABLE UNITS

1 unit min

d. FENESTRATION

First Floor Fenestration	20% min (2)
Upper Floor Fenestration	20% min (2)

e. STANDARDS

1. Uses in this building must be associated with tax-exempt organizations, such as museums, government, religious, educational institutions, etc. and provide a tangible civic benefit and be open to the public.
2. The Permitting Authority may waive window and door requirements for civic uses that require no windows for much of their exterior (such as art museums).
3. Civic buildings are exempt from roof system regulation. The values presented in E. Roof Types are guidelines only.

f. MASSING COMPONENTS

Rear Addition	●
Side Wing	●
Connector	●
Porte-Cochere	●
Tower	●

g. ARCHITECTURAL COMPONENTS

Porch	●
Gallery	●
Stoop	●
Cross Gable	●
Shed Dormer	●
Dormer Window	●
Bay Window	●
Balcony	●
Turret	●
Arcade	●
Portico	●
Canopy	●
Deck	●
Cupola	●

h. ROOFS

Gable Roof	●
Hipped Roof	●
Mansard Roof	●
Gambrel Roof	●
Shed Roof	●
Flat Roof	●

● Permitted

TABLE C - ACCESSORY BUILDING TYPE SUMMARY TABLE

1. BARN

2. FARMSTAND

3. CARRIAGE HOUSE

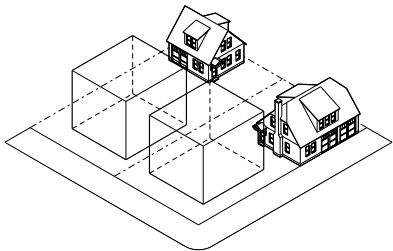
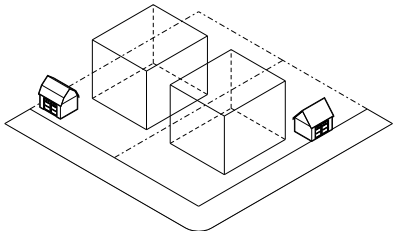
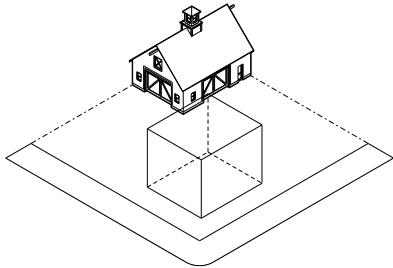

4. FABRICATION SHOP

5. ACCESSORY SHOP

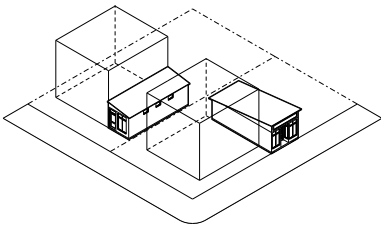
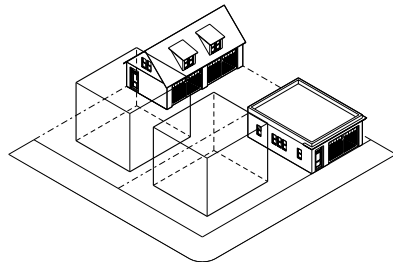

PAGE LEFT INTENTIONALLY BLANK

1. BARN

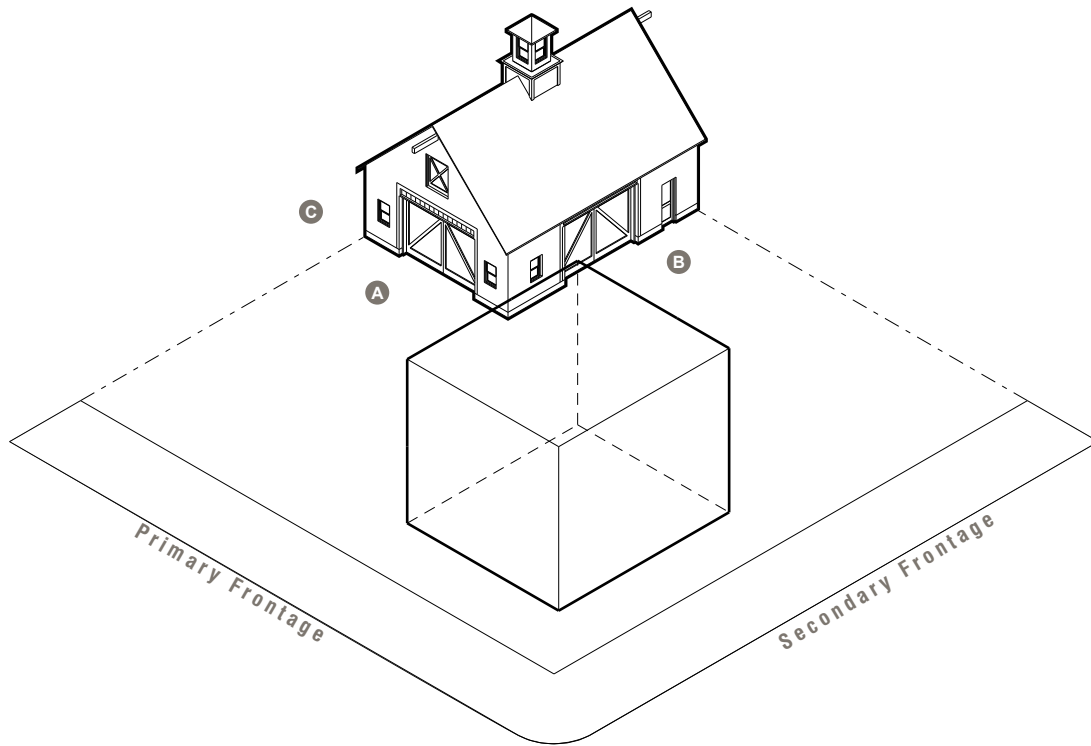

a. DESCRIPTION

A large accessory building that provides space for agricultural, fabrication, storage, or other permitted non-residential uses.

b. ACCESSORY BUILDING PLACEMENT

Primary Front Setback	(1)
Secondary Front Setback	3 ft min
Side Setback	3 ft min
Rear Setback	3 ft min

c. BUILDING FORM

Building Width	36 ft max (2)	A
Building Length	60 ft max (2)	B
Building Floor Plate	10,000 sf max (2)	
Total Stories	2 stories max	C
First Floor Height	n/a	
Upper Floor Height	n/a	
First Floor Elevation	0 ft min	
Roofs	see Section E Roof Types	
Attachments	none	

d. ALLOWABLE UNITS

1 unit max

e. FENESTRATION

First Floor Fenestration	optional
Upper Floor Fenestration	optional

f. STANDARDS

1. Barns must be set back at least 20 ft from the front facade of the primary building.
2. Barns may exceed maximum measurements for length and width when part of a working agricultural operation.
3. Barn doors located within the frontage zone must be sliding or swinging doors.
4. Shed dormers may ignore the gable end and ridge line setback in order to form a continuous monitor style roof along the entirety of the ridge beam.

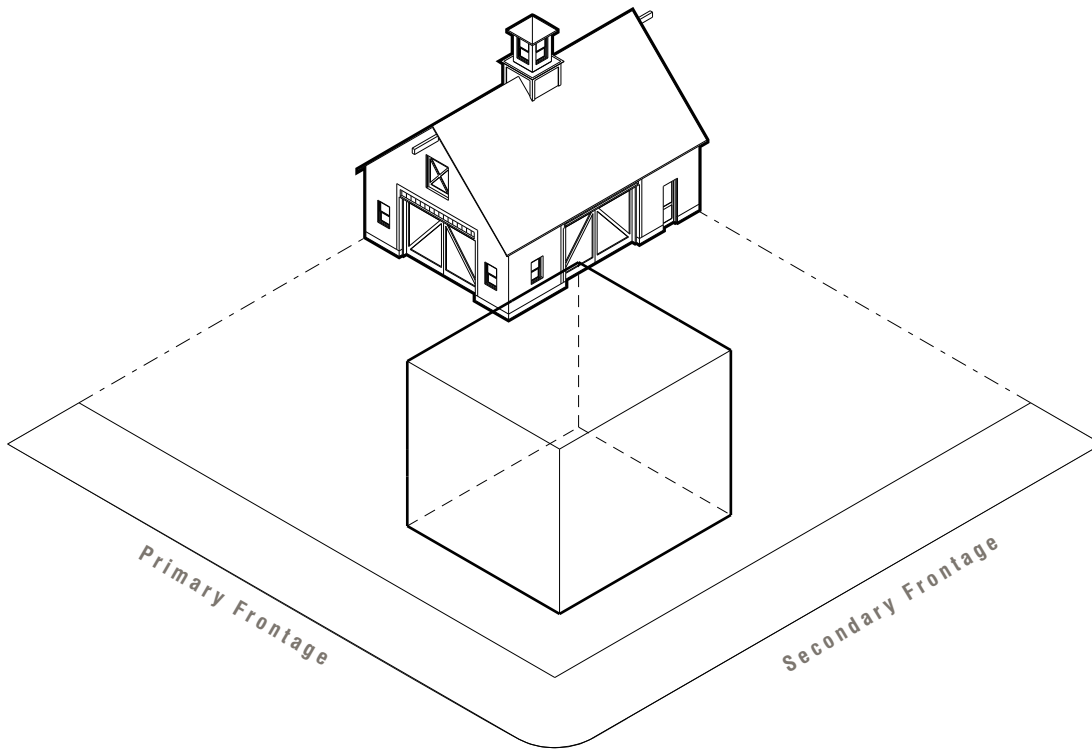

g. MASSING COMPONENTS

Rear Addition	●
Side Wing	●
Connector	●
Shed Dormer	●
Cross Gable	●
Tower	●

h. ARCHITECTURAL COMPONENTS

Stoop	●
Canopy	●
Dormer Window	●
Deck	●
Roof Deck	●
Cupola	●

i. ROOFS

Gable Roof	●
Gambrel Roof	●

● Permitted

2. FARMSTAND

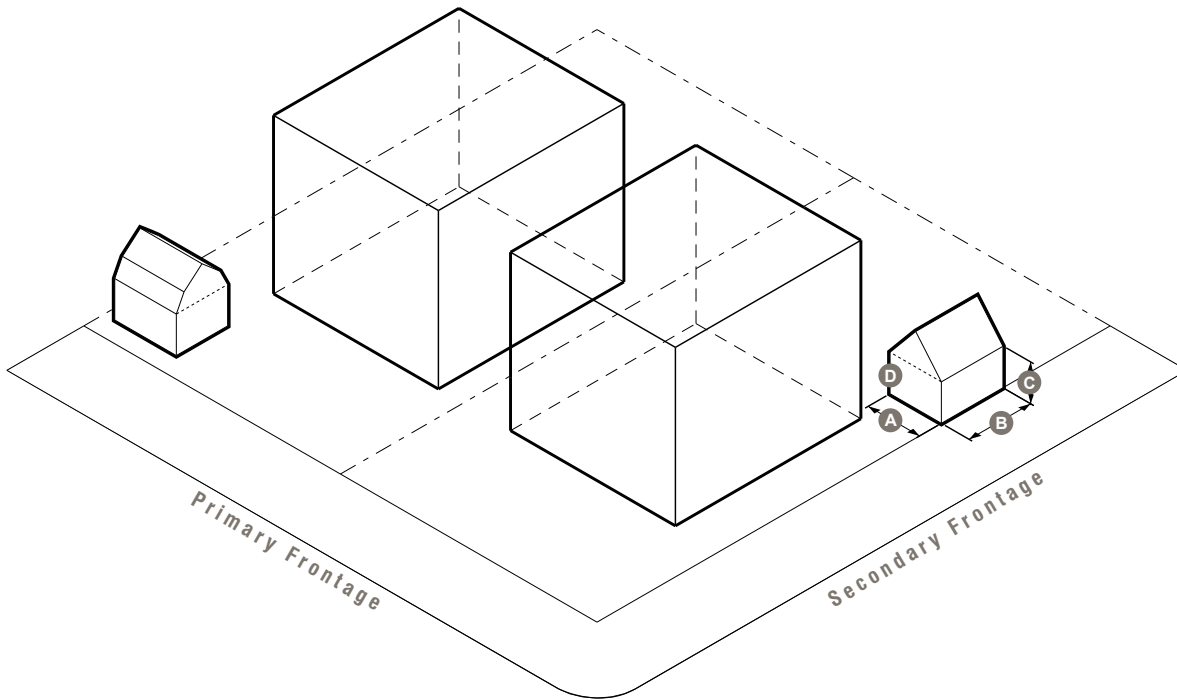

a. DESCRIPTION

An accessory building that is temporary or modular that provides space to sell agricultural products, or that temporarily alleviates a gap in a streetwall with a small commercial space.

b. ACCESSORY BUILDING PLACEMENT

Primary Front Setback	0 ft min
Secondary Front Setback	0 ft min
Side Setback	3 ft min
Rear Setback	3 ft min

c. BUILDING FORM

Building Width	12 ft max	(A)
Building Length	12 ft max	(B)
Total Stories	1 story max	(C)
First Floor Height	10 ft min, 15 ft max	(D)
Upper Floor Height	n/a	
First Floor Elevation	0 ft min	
Roofs	see Section E Roof Types	
Attachments	none	

d. ALLOWABLE UNITS

1 unit max

e. FENESTRATION

First Floor Fenestration	0% min
Upper Floor Fenestration	0% min

f. STANDARDS

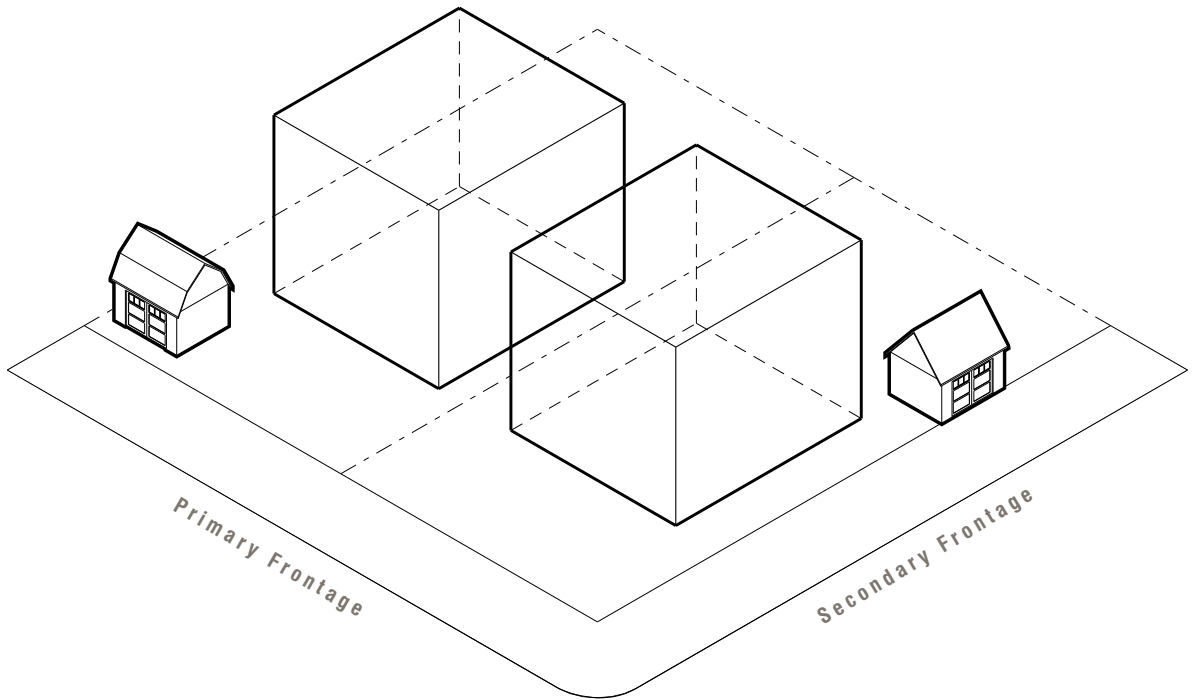

g. MASSING COMPONENTS

Porch	●
Shed Dormer	●
Cross Gable	●

h. ARCHITECTURAL COMPONENTS

Dormer Window	●
---------------	---

i. ROOFS

Gable Roof	●
Hipped Roof	●
Gambrel Roof	●
Shed Roof	●
Flat Roof	●

● Permitted

3. CARRIAGE HOUSE

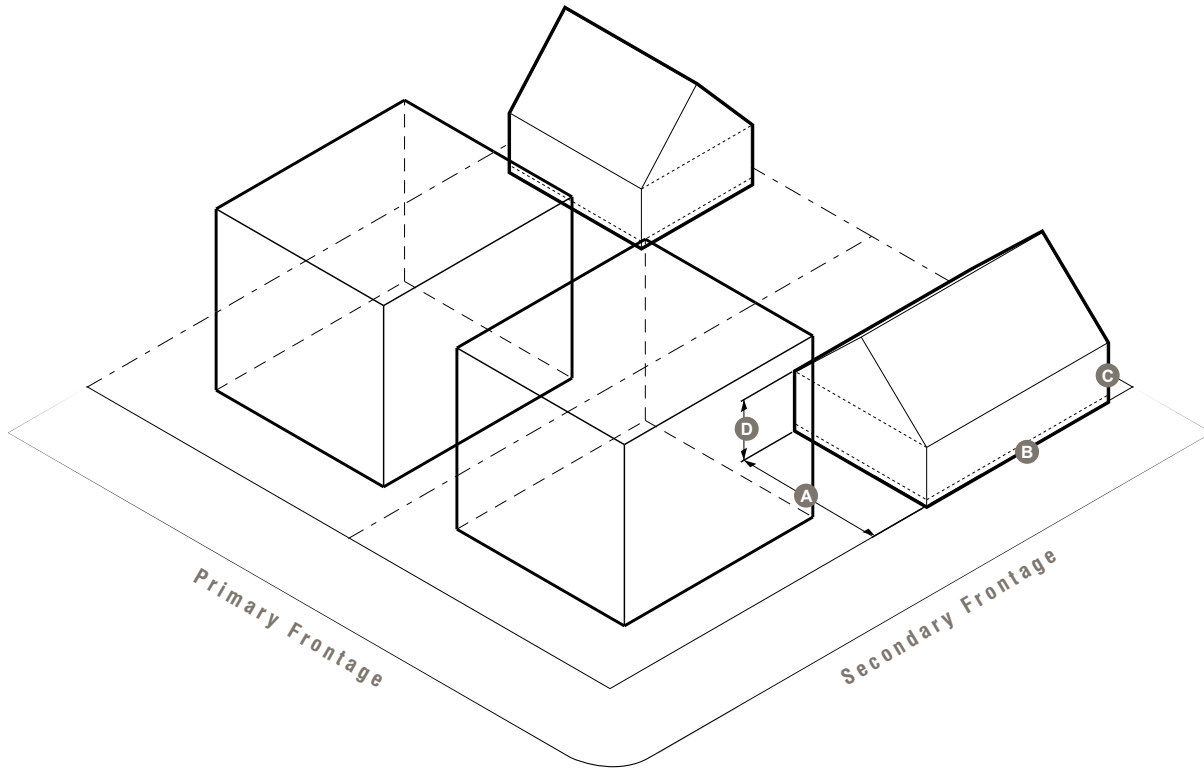

a. DESCRIPTION

An accessory building that provides space for parking, a workshop, an accessory unit, or a combination thereof.

b. ACCESSORY BUILDING PLACEMENT

Primary Front Setback	(1)
Secondary Front Setback	3 ft min
Side Setback	3 ft min
Rear Setback	3 ft min

c. BUILDING FORM

Building Width	24 ft max	(A)
Building Length	36 ft max	(B)
Total Stories	2 stories max	(C)
First Floor Height	9 ft min, 15 ft max	(D)
Upper Floor Height	9 ft min, 12 ft max	
First Floor Elevation	0 ft min	
Roofs	see Section E Roof Types	
Attachments	1 max	

d. ALLOWABLE UNITS

1 unit min

e. FENESTRATION

First Floor Fenestration	20% min
Upper Floor Fenestration	20% min

f. STANDARDS

- The carriage house must be set back at least 20 ft from the front facade of the primary building.

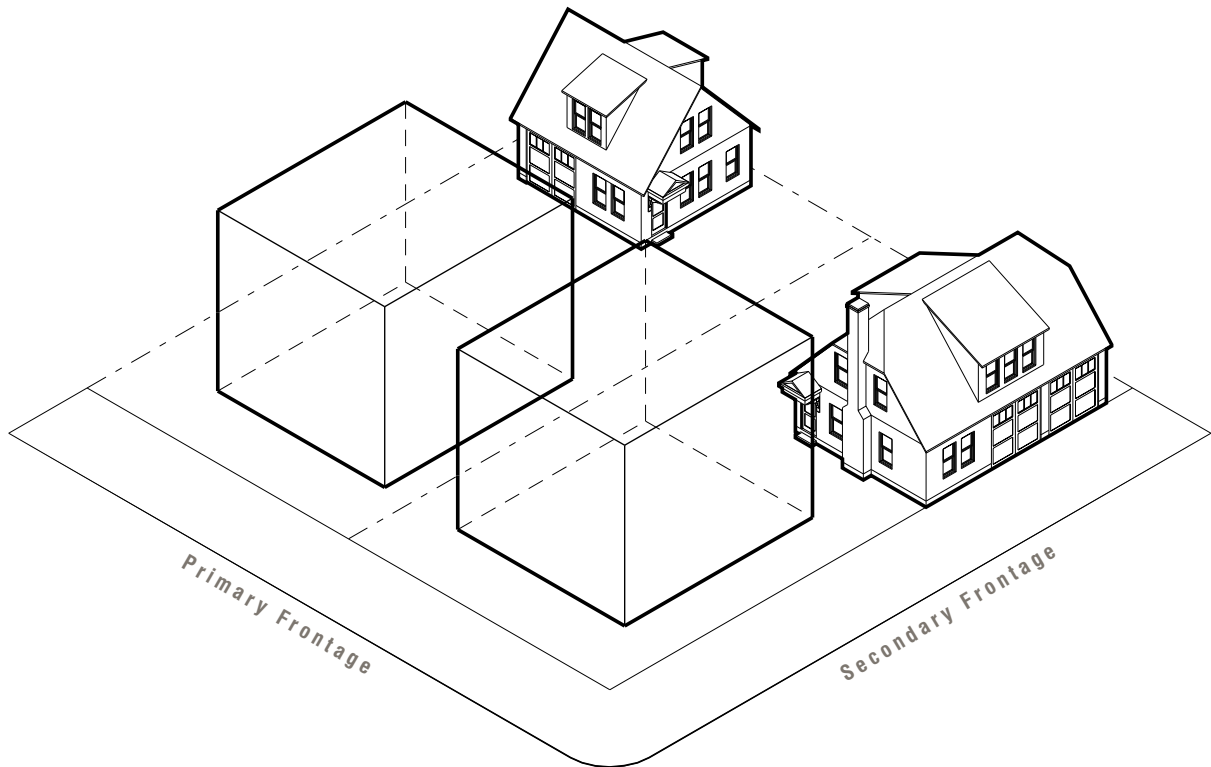

g. MASSING COMPONENTS

Porch	●
Gallery	●
Connector	●
Shed Dormer	●
Cross Gable	●
Porte-Cochere	●

h. ARCHITECTURAL COMPONENTS

Stoop	●
Canopy	●
Portico	●
Balcony	●
Bay Window	●
Dormer window	●
Deck	●
Roof Deck	●
Cupola	●

i. ROOFS

Hipped Roof	●
Gambrel Roof	●
Shed Roof	●
Flat Roof	●

● Permitted

4. FABRICATION SHOP

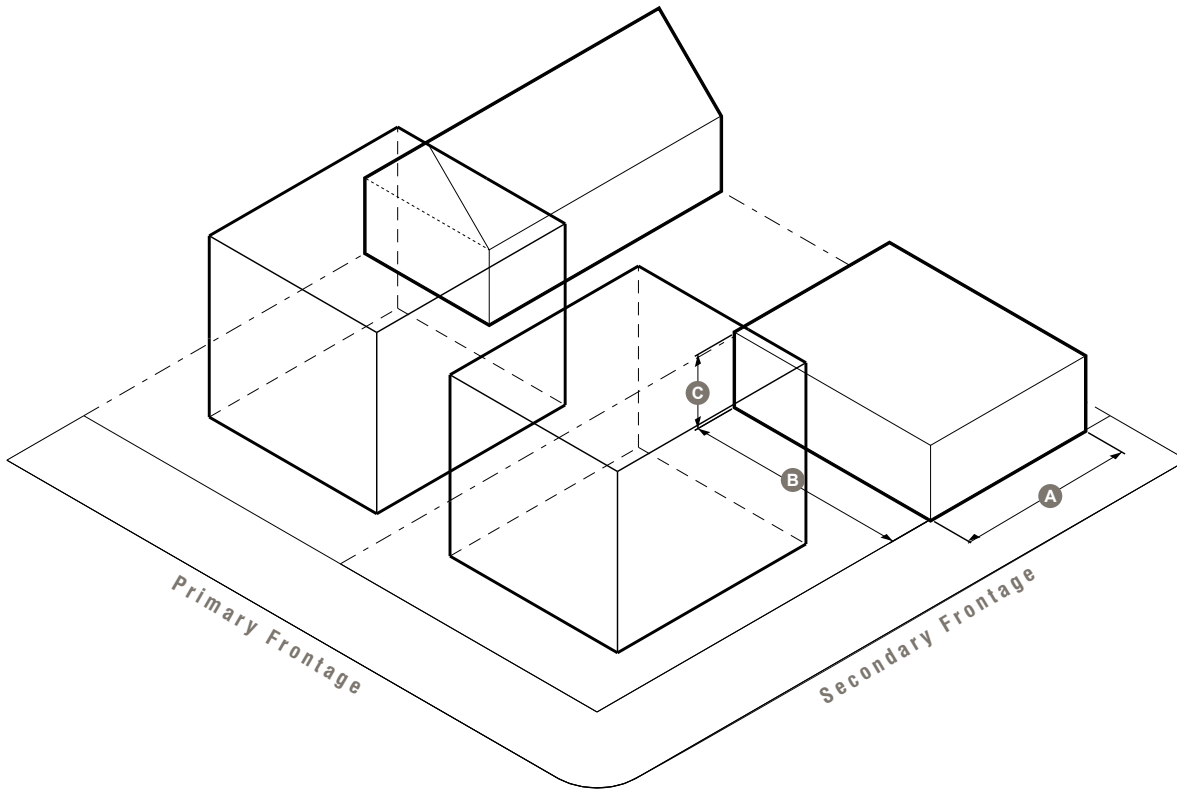

a. DESCRIPTION

An accessory building that provides space for fabrication uses.

b. ACCESSORY BUILDING PLACEMENT

Primary Front Setback	(1)
Secondary Front Setback	3 ft min
Side Setback	3 ft min
Rear Setback	3 ft min

c. BUILDING FORM

Building Width	30 ft max	(A)
Building Length	30 ft max	(B)
Total Stories	2 stories max	(C)
First Floor Height	9 ft min, 15 ft max	
Upper Floor Height	9 ft min, 12 ft max	
First Floor Elevation	0 ft min	
Roofs	see Section E Roof Types	
Attachments	1 max	

d. ALLOWABLE UNITS

1 unit max

e. FENESTRATION

First Floor Fenestration	20% min
Upper Floor Fenestration	20% min

f. STANDARDS

1. The fabrication shop must be setback at least 20 ft from the front facade of the primary building.

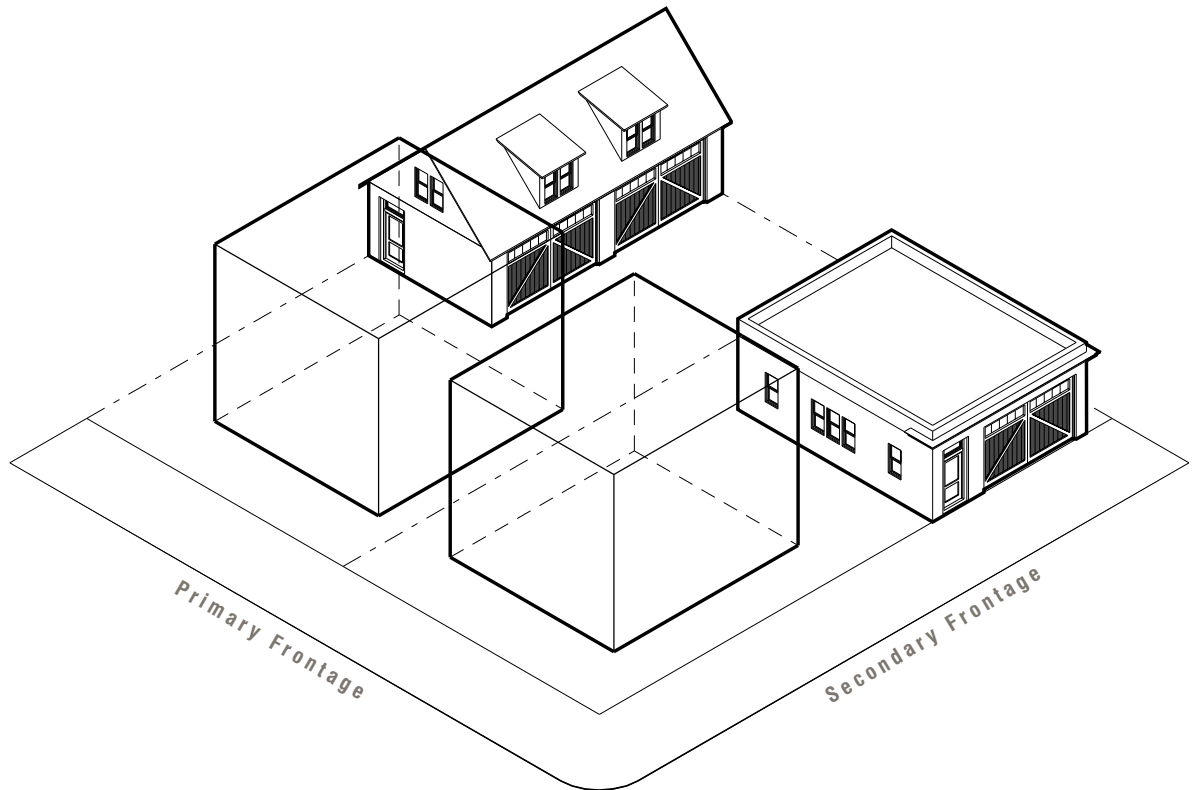

g. MASSING COMPONENTS

Porch	●
Gallery	●
Connector	●
Shed Dormer	●
Cross Gable	●
Porte-Cochere	●

h. ARCHITECTURAL COMPONENTS

Stoop	●
Canopy	●
Portico	●
Balcony	●
Bay Window	●
Dormer Window	●
Deck	●
Roof Deck	●
Cupola	●

i. ROOFS

Gable Roof	●
------------	---

● Permitted

5. ACCESSORY SHOP

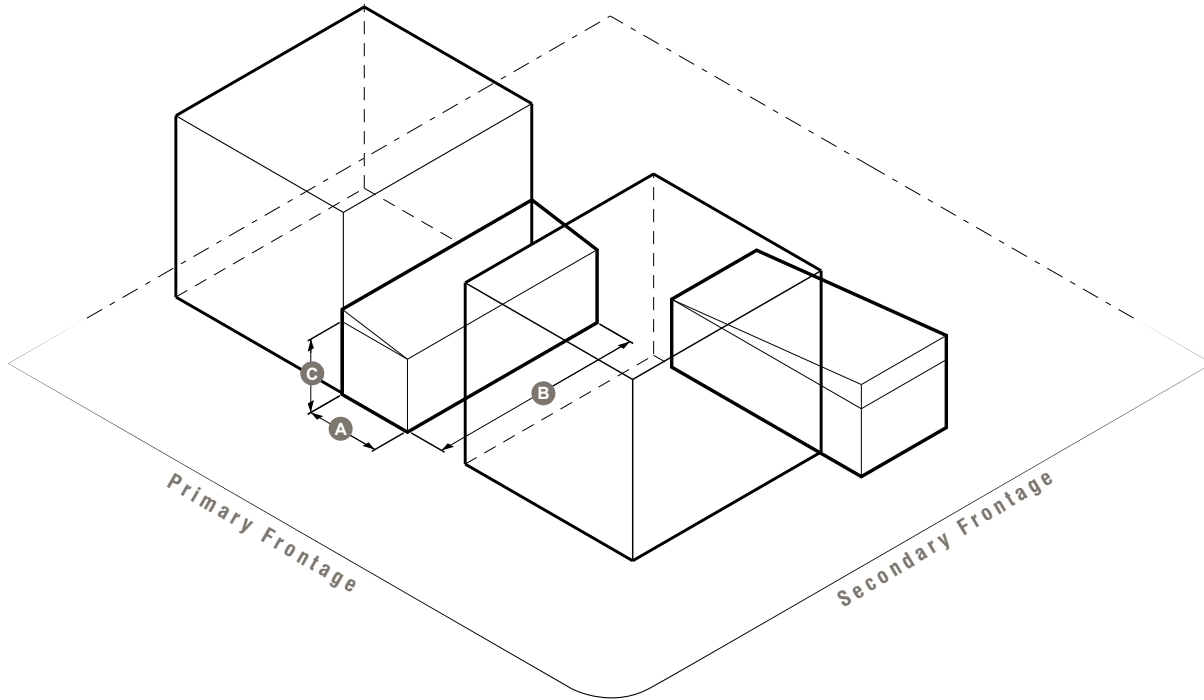

a. DESCRIPTION

An accessory building that provides space for commercial uses.

b. ACCESSORY BUILDING PLACEMENT

Primary Front Setback	0 ft min
Secondary Front Setback	0 ft min
Side Setback	0 ft min
Rear Setback	3 ft min

c. BUILDING FORM

Building Width	16 ft max	(A)
Building Length	36 ft max	(B)
Total Stories	1 story max	(C)
First Floor Height	10 ft min, 15 ft max	
Upper Floor Height	n/a	
First Floor Elevation	0 ft min	
Roofs	see Section E Roof Types	
Attachments	2 max	

d. ALLOWABLE UNITS

1 unit max

e. FENESTRATION

Shopfront	required
First Floor Fenestration	70% min
Upper Floor Fenestration	n/a

f. STANDARDS

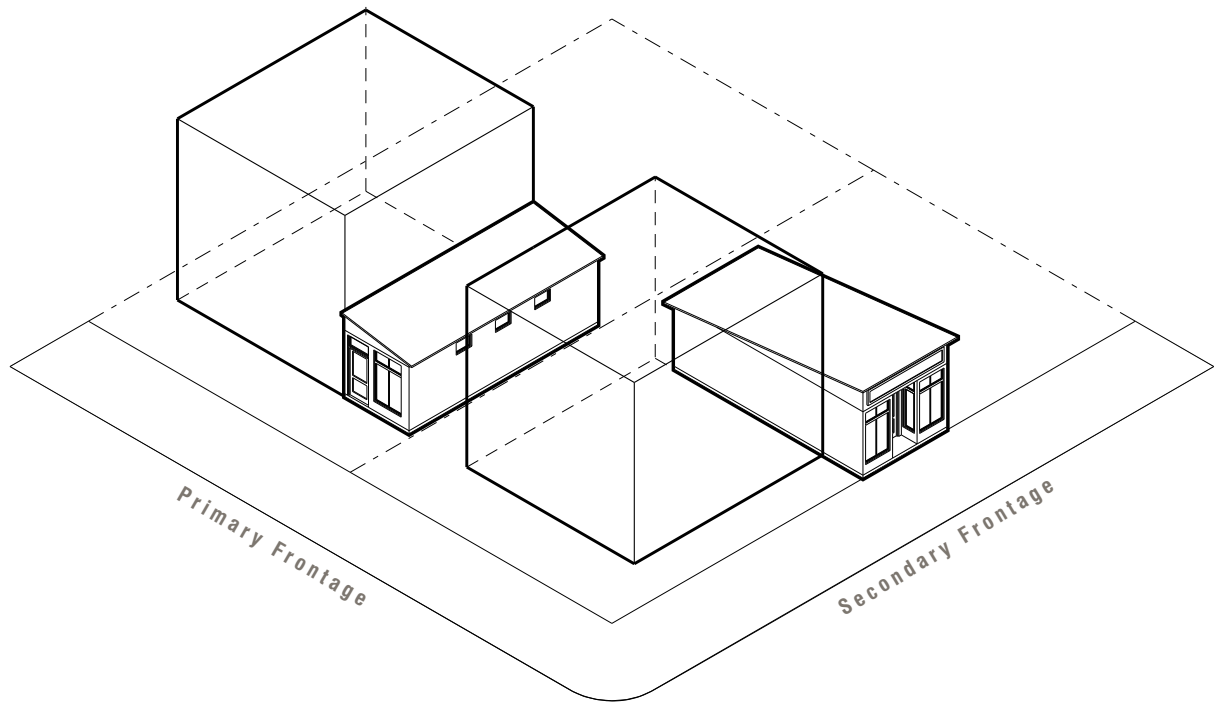

g. MASSING COMPONENTS

Porch	●
Gallery	●
Connector	●
Shed Dormer	●
Cross Gable	●
Arcade	●
Porte-Cochere	●
Extended Shopfront	●

h. ARCHITECTURAL COMPONENTS

Stoop	●
Canopy	●
Portico	●
Bay Window	●
Dormer Window	●
Deck	●
Roof Deck	●

i. ROOFS

Gable Roof	●
Hipped Roof	●
Gambrel Roof	●
Shed Roof	●
Flat Roof	●

● Permitted

1. PORCH

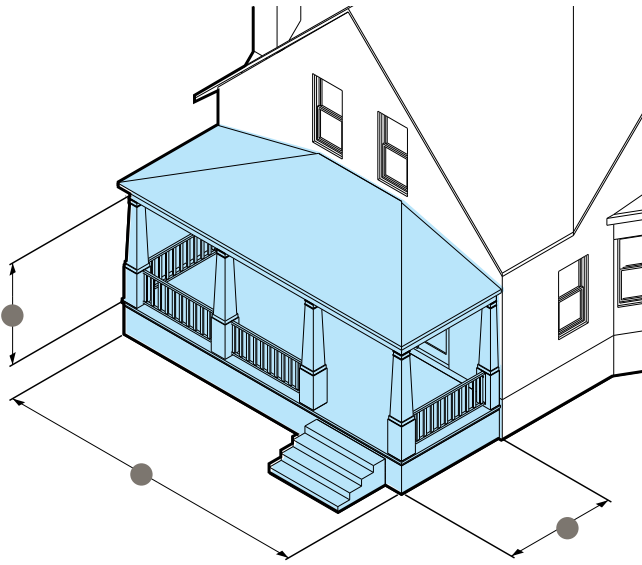

a. DESCRIPTION

A raised platform with stairs that provides access to a building entrance.

b. DIMENSIONS

Width	No more than the width of the adjoining building face	A
Projection	6 ft min, 12 ft max	B
Height	7 ft min	C
Fenestration	60% min when enclosed	

c. STANDARDS

1. Porches may be partially or fully enclosed.
2. Porches may be projecting, engaged, or integral.
3. Porches may wrap around corners to attach to porches, galleries, decks, or balconies on abutting building faces.
4. Stairs may extend off the front or side of the porch, except when a porch is located on an upper floor in which case the stairs cannot be located along the primary frontage.
5. When built on an upper floor, porches must be supported from below by a porch, arcade, or other supporting component; or visually supported by brackets, corbels, or beams along its full depth.
6. When built at the first floor, the space between piles or piers must be enclosed with latticework or similar material, or concealed visually by evergreen landscaping, on all sides.

2. GALLERY

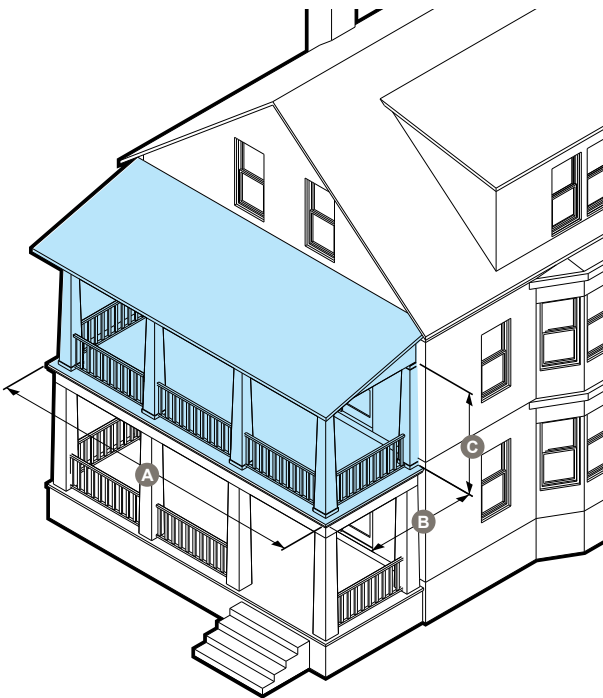

a. DESCRIPTION

A raised, roofed platform that provides additional living space, with access solely from the interior of a building.

b. DIMENSIONS

Width	No more than the width of the building face to which it attaches	A
Projection	6 ft min, 12 ft max	B
Clear Height	7 ft min	C
Fenestration	60% min when enclosed	

c. STANDARDS

1. Galleries may be partially or fully enclosed.
2. Galleries may be projecting or integral.
3. Galleries may wrap around corners to attach to porches, decks, balconies, or other galleries on abutting building faces.
4. When built on an upper floor, galleries must be supported from below by a porch, arcade, or other supporting component; or visually supported by brackets, corbels, or beams along its full depth.
5. When built at the first floor, the platform must extend visually to the ground plane.

3. SIDE WING

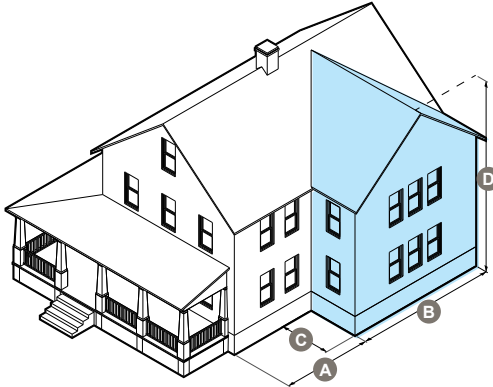

a. DESCRIPTION

A multi-story extension from the side walls of a primary building or accessory building.

b. DIMENSIONS

Setback from Facade	8 ft min	A
Width	max 2/3 width of primary building	B
Projection	max 2/3 depth of primary building	C
Absolute Height	Equal to or less than height of primary building	D
Fenestration	20% min	

c. STANDARDS

1. Side wings may not encroach on setbacks.
2. The primary building may only have one side wing per side.
3. Side wings may be centered or offset at the side wall of the primary building, provided they share at least 6 ft with the common wall.
4. A side wing may only attach to a primary or accessory building, though other components may attach to it.
5. The side wing may be used for vehicular parking, provided the garage doors are not within the frontage zone.

4. REAR ADDITION

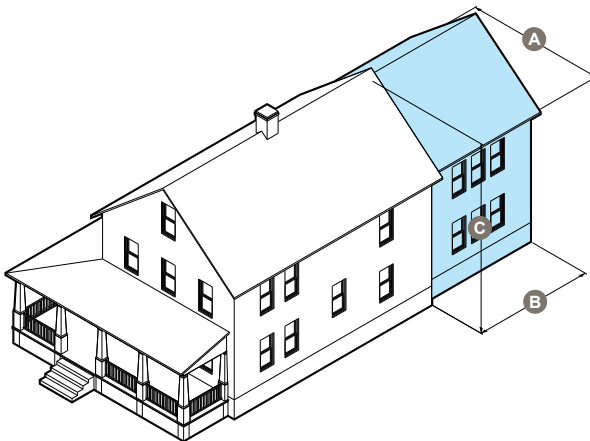

a. DESCRIPTION

An extension from the rear wall of a primary building or accessory building.

b. DIMENSIONS

Width	Max width of rear wall, less 2 ft	A
Projection	Less than or equal to the width of the main building mass	B
Height	Equal to or less than height of main building mass	C
Fenestration	20% min	

c. STANDARDS

1. Rear additions may not encroach on setbacks.
2. The primary building may only have one rear addition.
3. Rear additions may be centered or offset at the rear wall of the main building mass, provided they share at least 6 ft with the common wall.
4. The rear addition may be used for vehicular parking, provided the garage doors are not within the frontage zone.

5. STOOP

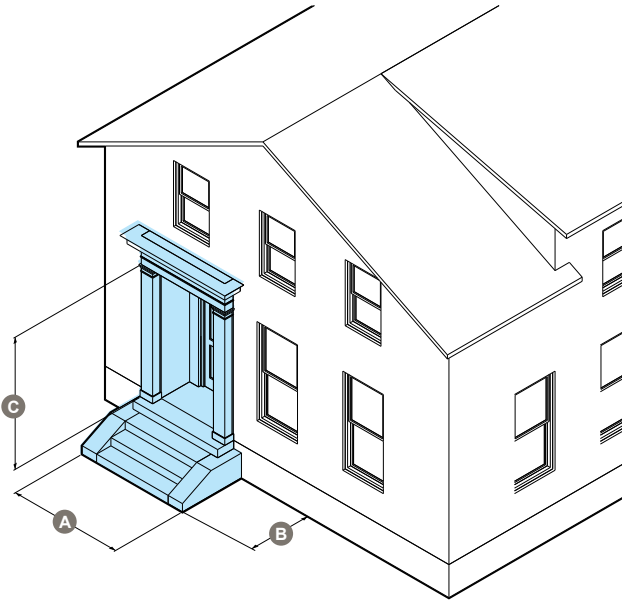

a. DESCRIPTION

A component type featuring a set of stairs with a landing leading to the entrance of a building.

b. DIMENSIONS

Width	3 ft 6 in min	A
Projection	3 ft 6 in min	B
Height	7 ft min when recessed	C

c. STANDARDS

1. Stoops may be recessed into the building facade.
2. Stoop may be built perpendicular or parallel to the building face, but must lead directly to ground level or an abutting sidewalk from the building entrance.
3. A Recessed stoop may not be enclosed.
4. Stoops, when built as part of a townhouse or live/work flex building, may be configured as a split stair to access a below grade unit.
5. If a stoop is built encroaching onto a public sidewalk, it must provide at least 3 ft clear and unobstructed space between its outermost face and the face of the curb.

6. CONNECTOR

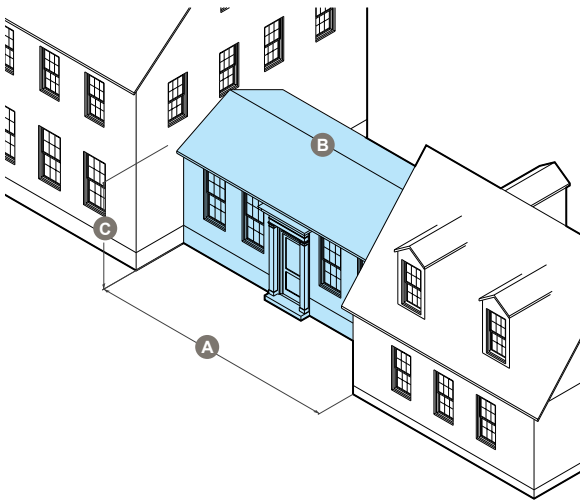

a. DESCRIPTION

A narrow, roofed extension meant to link a main building mass to an accessory building or to a component of an accessory building.

b. DIMENSIONS

Length	Equal to or less than the length of the primary building	A
Width	8 ft min, max 2 feet less than the narrowest building face or component face to which it attaches.	B
Absolute Height	May be one or more stories in height, but may not exceed the eave height of the smallest building element to which it is linked.	C
Fenestration	10% min	

c. STANDARDS

1. Must attach on at least one side to the primary building.
2. Connectors may not encroach on setbacks.

7. CROSS GABLE

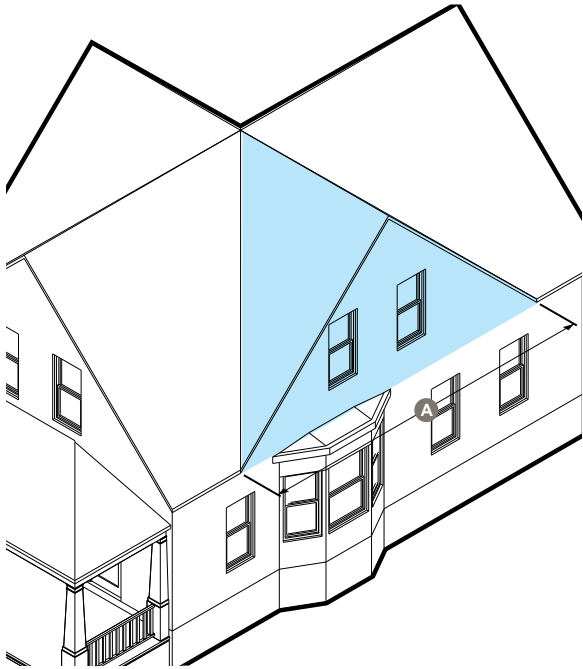

a. DESCRIPTION

A gable or gambrel roof that projects perpendicular from the roof of the primary building to increase the habitable space within a roof.

b. DIMENSIONS

Width	Equal to eave width of the narrowest face of the primary building.	A
Height	The ridge beam of the cross gable may not be higher than the ridge beam of the primary building.	B
Fenestration	20% min	

c. STANDARDS

1. Cross Gables may project outward from a building face (to a maximum of 12 ft) if supported from below by a component or visually supported by brackets, corbels, or a beam.
2. Two cross gables of equal size and roof pitch may be used together and may occupy the same space, but may not overlap.

8. SHED DORMER

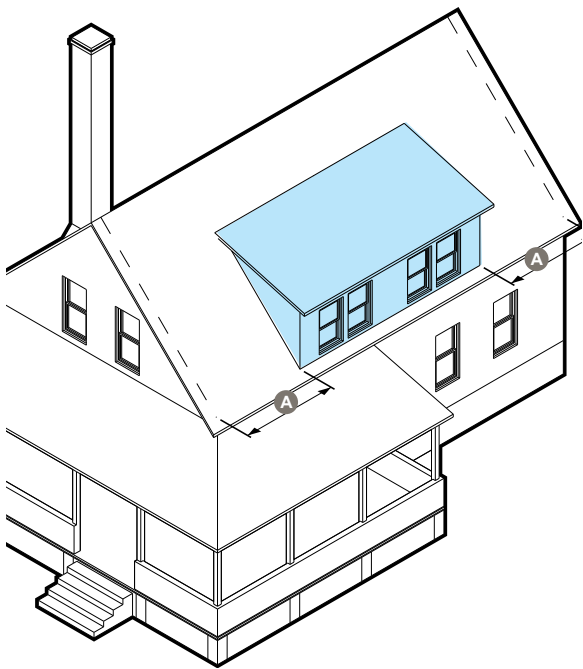

a. DESCRIPTION

A room, or portion of a room with a shed roof that projects vertically from the roof or building element, designed to provide increased light and expand the habitable space under a roof.

b. DIMENSIONS

Gable End Setback	1 ft min (3)	A
Fenestration	20% min	

c. STANDARDS

1. The face of the shed dormer must not project beyond the building eaves.
2. Gable end setbacks may be 0 ft from the building face when not visible from a thoroughfare (not including alleys).

9. DORMER WINDOW

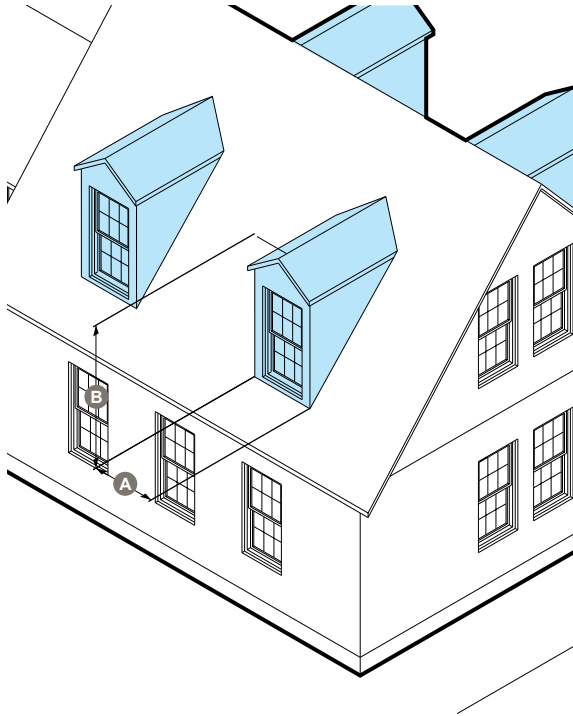

a. DESCRIPTION

A window or group of up to 3 windows with a gable, hip, or shed roof that projects vertically from the roof a building element, designed to provide increased light and expand the habitable space within a roof.

b. DIMENSIONS

Width	(2)	A
Height	(4)	B

c. STANDARDS

1. The window(s) in a dormer window should be vertically proportioned and no more than 3 ft wide.
2. The total width of a dormer window must be no more than 18 inches wider than the rough opening required for its' windows.
3. The face of the dormer window must not project beyond the building eaves.
4. When attached to a mansard or gambrel roof, the eave of the dormer may not pass above the chine of the roof.

10. BAY WINDOW

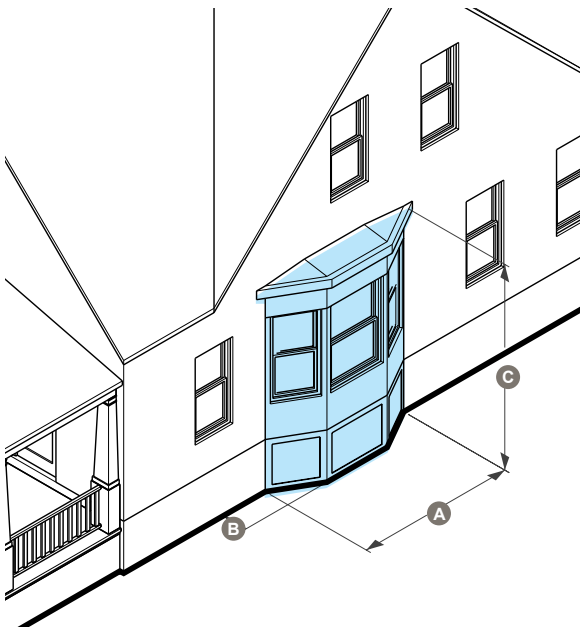

a. DESCRIPTION

A enclosed window assembly extending from the face of a building element to permit increased light, multi-directional views, and articulate a building facade.

b. DIMENSIONS

Width	16 ft max	A
Projection	6 in min, 4 ft max	B
Top Plate Height	Max equal to total number of full building stories.	C
Fenestration	30% min	

c. STANDARDS

1. Bay windows must be visually supported by brackets, corbels, or a beam along their full depth or, when built at the first floor, may extend visually to the ground plane.
2. Bay windows may only attach to the main building mass, additions, accessory buildings, towers, porte-cocheres, connectors, cross-gables, and extended shopfronts.
3. Bay windows may intersect with and occupy the same space as porches, balconies, galleries, arcades, and decks.
4. Bay windows must attach to a single building face and may not wrap around corners.
5. Bays windows may be two sided, multi-sided, or curved.
6. Bay windows may provide openings for doorways or windows.

11. BALCONY

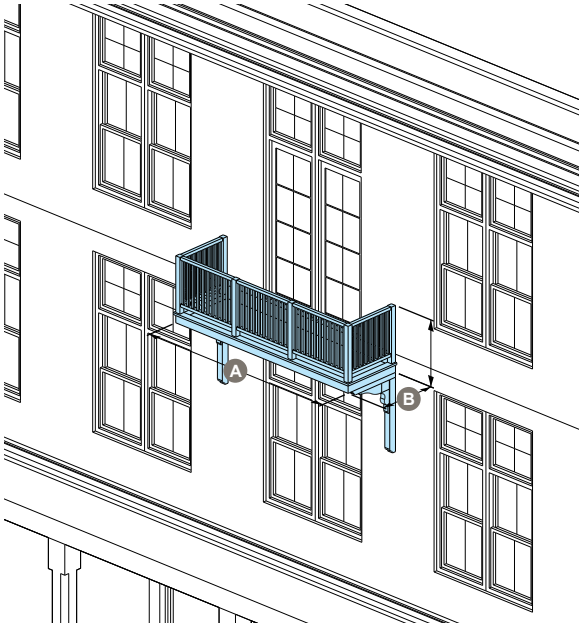

a. DESCRIPTION

An unroofed platform attached to a building face with a railing that provides outdoor space above the first floor.

b. DIMENSIONS

Width	No more than the width of the adjoining building face.	A
Projection	8 ft max	B

c. STANDARDS

- Balconies are only permitted on upper stories.
- Balconies may not be enclosed and must be unroofed unless it is recessed into the envelope of the building or component to which it is attached.
- Balconies may be projecting, integral, terraced, or a combination thereof.
- Balconies may wrap around corners to attach to galleries, porches, decks, or balconies on abutting building faces.
- A balcony must be visually supported by brackets, corbels, or beams along its full width, or physically supported by another component.
- A projecting balcony must have a clear height above the ground of at least 10 ft.
- The railing of any balcony oriented toward a frontage must have posts and railings with spacing, except when recessed into the envelope of the building to which it is attached.
- When built above a porch, gallery, portico, or arcade, the balcony may extend to the boundaries of the component below.

12. EXTENDED SHOPFRONT

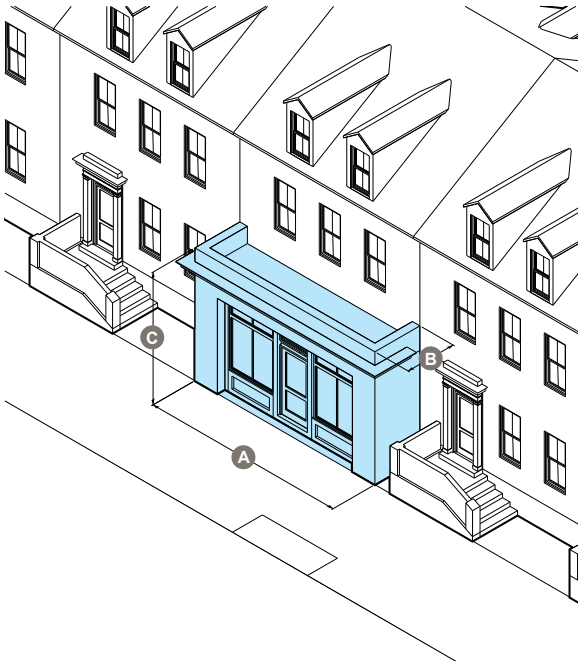

a. DESCRIPTION

An extension on the front of a building to provide new or expanded commercial space and a shopfront.

b. DIMENSIONS

Width	No more than the width of the building face to which it attaches.	A
Projection	0 ft min	B
Height	Max equal to total number of full building stories.	
Fenestration	70% min (Shopfront) 30% min (Upper Stories)	

c. STANDARDS

- Extended shopfronts may wrap around corners to join with an accessory shop or another extended shopfront on another building face.
- Extended shopfronts may not attach to accessory buildings with the exception of an accessory shop.
- Only 1 extended shopfront is allowed per building face.

13. TURRET

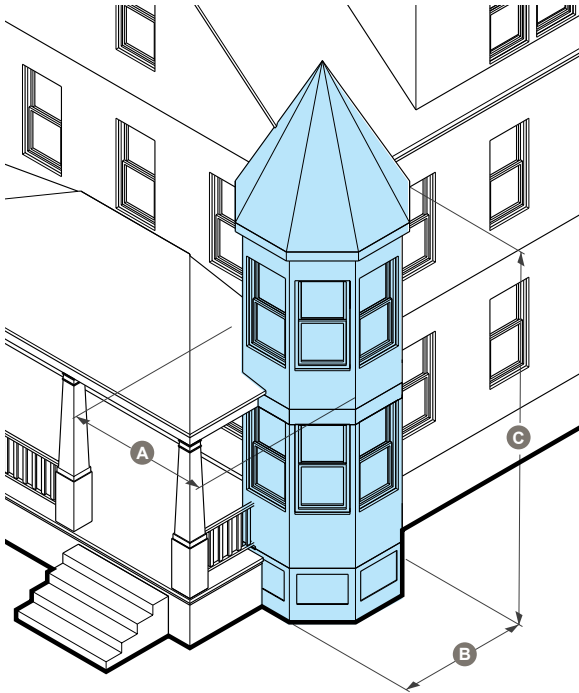

a. DESCRIPTION

A small, decorative, tower-like extension from the wall or corner of a building, meant to provide distinctive living space or to terminate an important axis.

b. DIMENSIONS

Length	8 ft max	A
Width	Must be equal to length	B
Height	The top plate of a turret may not exceed the height of the top plate of the adjoining building.	C
Fenestration	30% min	

c. STANDARDS

1. Turrets must be visually supported by brackets, corbels, or a beam along their full width, or physically supported by another component.
2. Turrets may be square, multi-sided, or curved, and must possess radial symmetry.
3. Turrets may wrap around corners.
4. Turrets may intersect with and occupy the same space as porches, balconies, galleries, arcades, and decks.
5. Turrets must extend beyond the building face(s) to which they are attached.
6. The highest point of the roof of a turret may be higher than the highest point of the roof of the primary building.

14. ARCADE

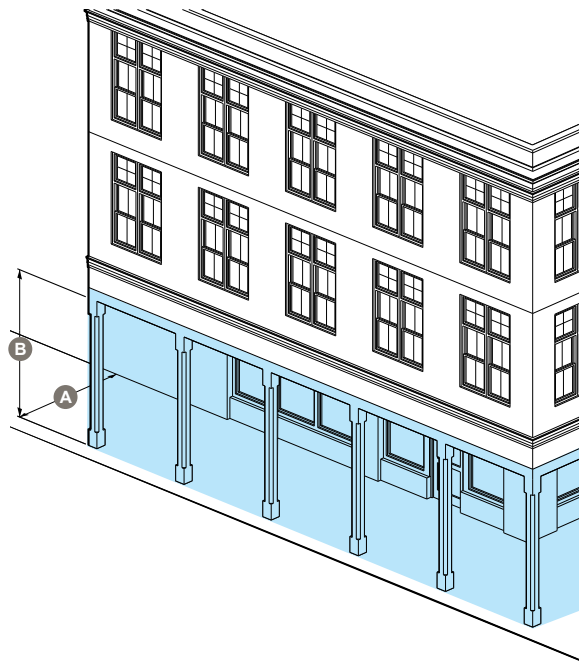

a. DESCRIPTION

A ground-level roofed structure that provides cover and is supported on regularly spaced pillars, columns, or archways.

b. DIMENSIONS

Width	n/a	
Projection	8 ft min and no more than the height of the first floor of the main building mass.	A
Height	8 ft min	B
Fenestration	70% min when enclosed	

c. STANDARDS

1. Arcades may be projecting or integral.
2. Arcades may be partially or fully enclosed with windows, doors, or decorative ironwork provided they maintain at least 90% transparent openings.
3. When projecting over a sidewalk must extend the full width, less 2 ft.
4. Arcades located along a primary or secondary frontage, or within the town right-of-way may not be enclosed.
5. Arcades may wrap around corners to attach to other arcades on abutting building faces.

15. PORTE-COCHERE

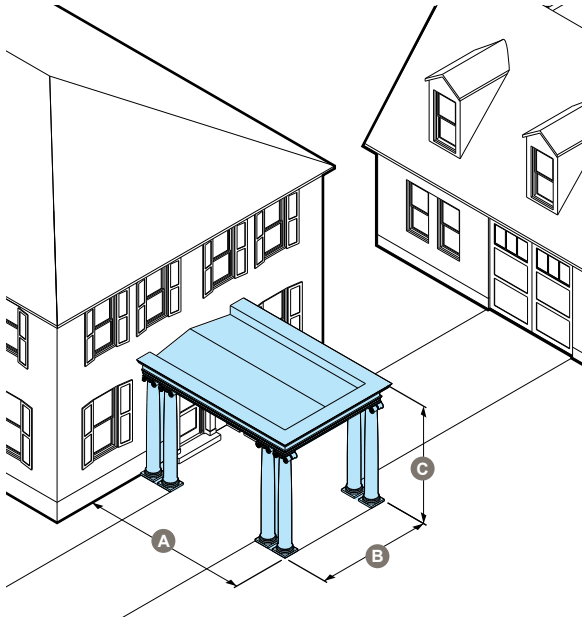

a. DESCRIPTION

A roofed, building element through which a vehicle may pass, and that provides shelter from inclement weather.

b. DIMENSIONS

Width	16 ft max (4)	(A)
Projection	9 ft min (4)	(B)
Height	1 Story (4)	(C)

c. STANDARDS

1. Porte-cocheres may link any two buildings or components.
2. Front and back faces of the porte-cochere must have openings of dimension sufficient to pass a vehicle through at the ground level.
3. Carriage House-style lifting doors are not permitted on a porte-cochere.
4. When associated with a commercial drive-through, the following standards apply, replacing any above standards as required:
 - a. When located on the side of a building, a porte-cochere must be attached to the primary building, must be shorter than the eave of the building or no more than 16 ft in absolute height (whichever is lesser), and may not project more than 12 ft.
 - b. When located on the side of a building, porte-cochere materials should match the materials used on the primary building.

16. PORTICO

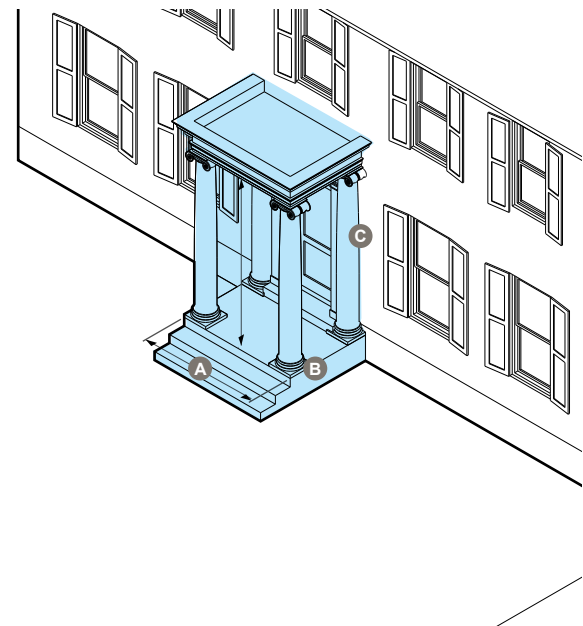

a. DESCRIPTION

A roofed structure above a stoop or platform supported on columns or pillars, which shields occupants from inclement weather and provides access to a building entrance.

b. DIMENSIONS

Width	3 ft 6 in min	(A)
Projection	3 ft 6 in min, 8 ft max	(B)
Height	8 ft min	(C)
Fenestration	n/a	

c. STANDARDS

1. No span between columns or pillars may be larger than the height of adjacent columns or pillars.
2. A portico may not exceed the height of the primary ridge beam on the building element to which it attaches.
3. A portico must be elevated on a platform at least 1 foot from the surface of the ground.

17. CANOPY

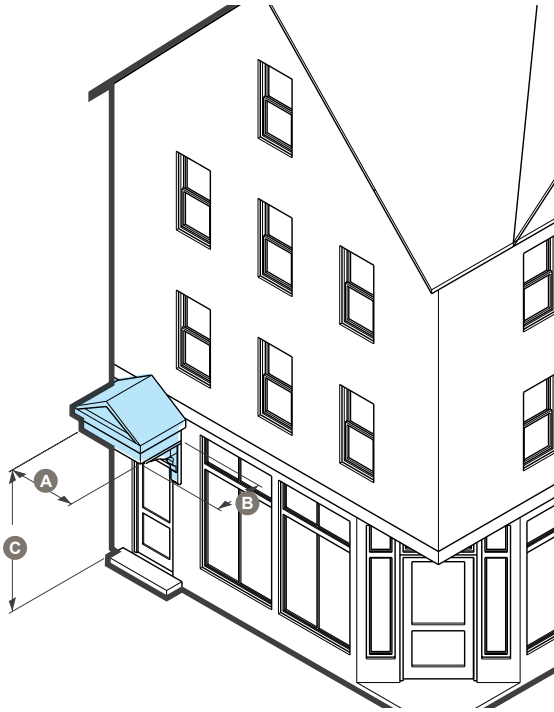

a. DESCRIPTION

A fixed, wall mounted overhang extending from a building to provide shade and weather protection for pedestrians.

b. DIMENSIONS

Width	4 ft min	A
Projection	3 ft min	B
Height	8 ft min	C

c. STANDARDS

1. Canopies should be visually supported on wood or metal brackets, or suspended by cable or chain.
2. Canopies should be inset from the corners of the wall to which they are attached by at least 3 inches.

18. DECK

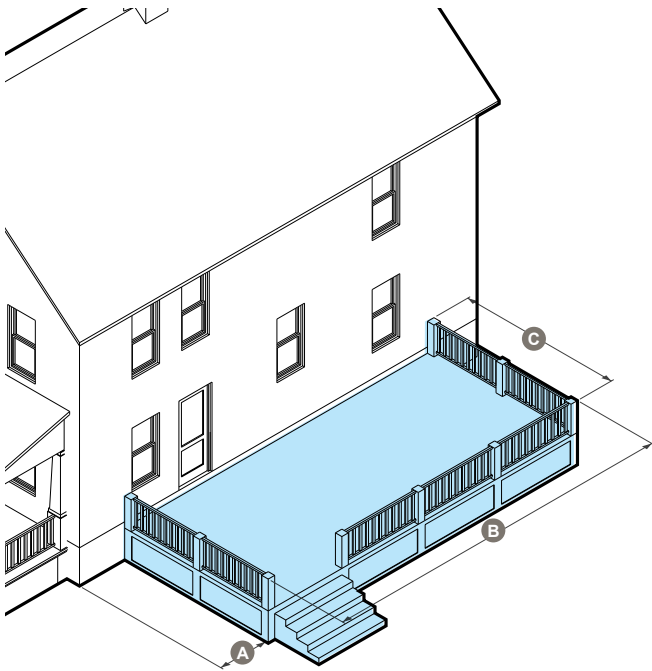

a. DESCRIPTION

A roofless, uncovered, raised platform accessible from a secondary entrance to a building that provides outdoor amenity space.

b. DIMENSIONS

Setback from Facade	2 ft min	A
Width	8 ft min	B
Projection	6 ft min	C
Height	none	
Fenestration	none	

c. STANDARDS

1. Decks are not permitted along frontages.
2. The space between piles or piers must be enclosed with latticework or similar material, or concealed visually by evergreen landscaping, on all sides, except for decks that are elevated more than 8 ft from the ground plane.
3. Decks may not be enclosed.

19. TOWER

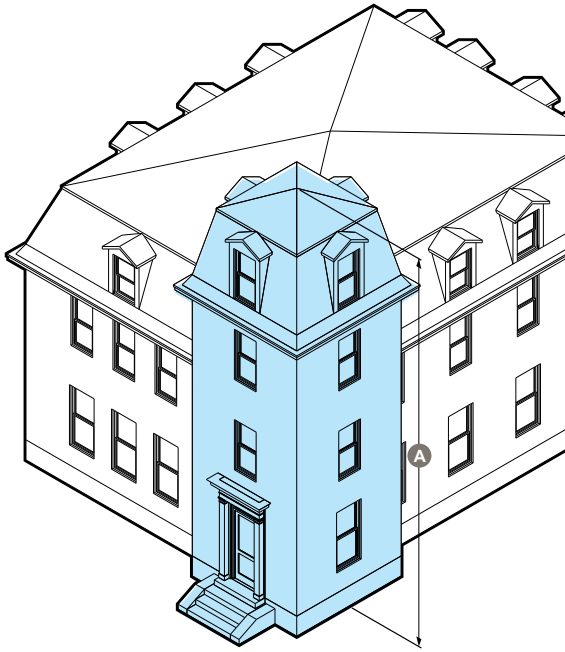

a. DESCRIPTION

A building component that is significantly taller than it is wide as way to gain views and additional habitable space.

b. DIMENSIONS

Area	200 sf max
Height	Maximum of one story above the highest story not contained within a roof. A
Fenestration	30% min (8)

c. STANDARDS

1. Towers must attach to the main building mass.
2. Towers must be constructed on a foundation that extends to the ground plane.
3. Towers may be square, multi-sided, or curved, but should possess radial symmetry.
4. Towers may intersect with and occupy the same space as porches, galleries, arcades, and decks.
5. Towers may extend horizontally beyond the building face(s) to which they are attached.
6. 1 tower per lot max.
7. The highest point of a tower may extend above the highest point of the roof of the primary building.
8. Towers built as silos on a barn may ignore widow and door requirements.

20. ROOF DECK

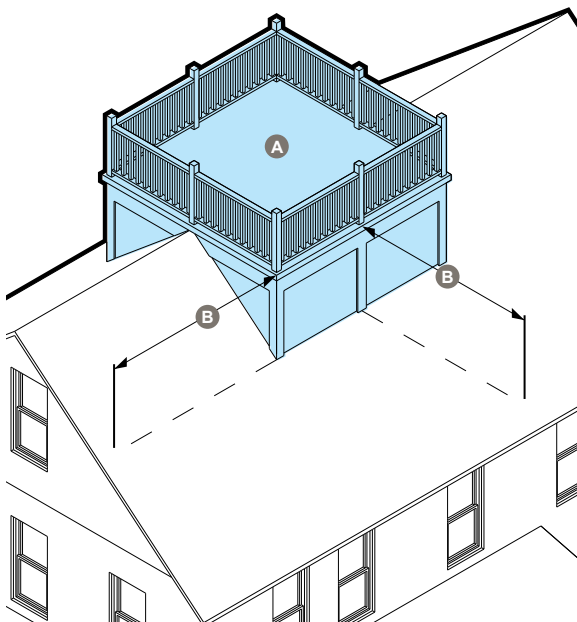

a. DESCRIPTION

A raised uncovered platform with a railing on the roof of a building that provides outdoor amenity space and access to views.

b. DIMENSIONS

Total Area	400 sq ft max	A
Setback from Building Faces	5 ft min from every building face (3)	B

c. STANDARDS

1. The width of roof decks may not exceed 50% of the building width, except on a flat roof they may extend to fill the entire roof.
2. The railing must be constructed with posts and rails with spacing such that it does not exceed 50% opacity, except when built on a flat roof.
3. Roof decks built on a flat roof may extend to the building parapet and use the parapet as a railing, provided it is of sufficient height.
4. Roof decks may only be built on the main roof of a primary, building accessory building, rear additions, side wings, connectors, galleries, and porches.
5. The highest point of a roof deck may be higher than the highest point of the roof of the primary building.

21. CUPOLA

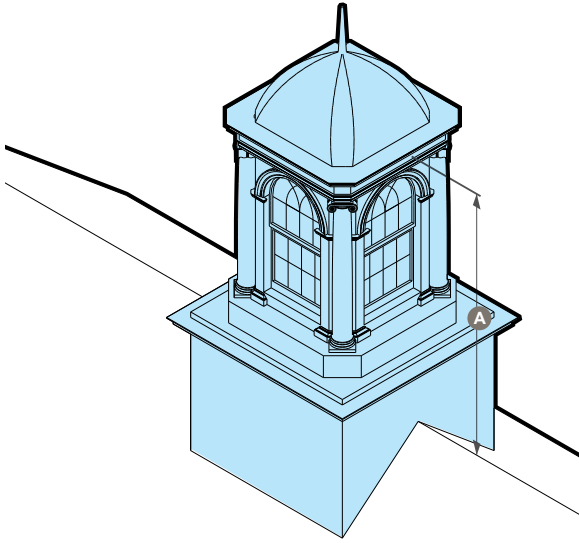

a. DESCRIPTION

A small roof structure, possessing radial symmetry, used to provide light and ventilation to a building, or as a belfry, overlook, lantern, or additional habitable space.

b. DIMENSIONS

Length	A
Width	B
Height	C
Fenestration	40% min

Less than or equal to the maximum upper floor height for the main building mass or accessory building to which it is attached, measured from the top of the primary ridge beam to the base of the cupola's eaves.

c. STANDARDS

1. A cupola's maximum area must be no greater than 150 SF.
2. Cupolas may only attach to the main building mass, roof decks, towers, porte-cocheres, and accessory buildings.
3. The highest point of a cupola may be higher than the highest point of the roof of the primary building.

PAGE LEFT INTENTIONALLY BLANK

1. GABLE ROOF

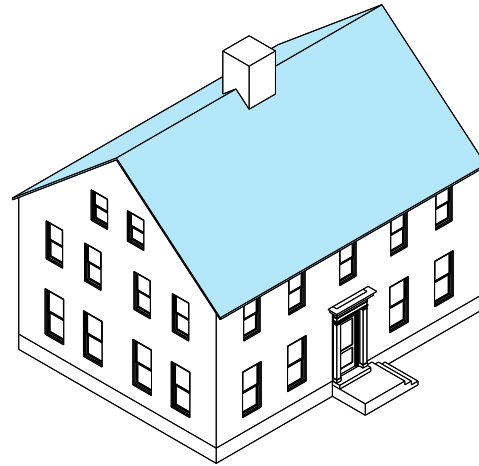
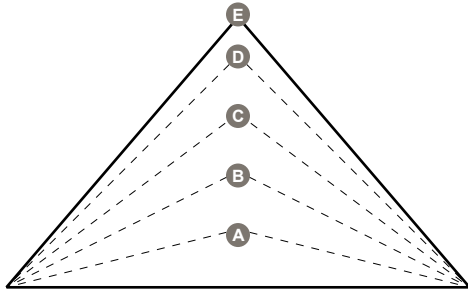

a. DESCRIPTION

A pitched roof with two sides of the same slope and length, meeting symmetrically at a single ridge-beam.

b. ROOF PITCH BY BUILDING TYPE

Cottage	6:12 Min, 14:12 Max	B E
House	8:12 Min, 14:12 Max	C E
Bungalow	6:12 Min, 14:12 Max	B E
Duplex	8:12 Min, 14:12 Max	C E
Apartment House	9:12 Min, 14:12 Max	C E
Apartment Building	9:12 Min, 14:12 Max	C E
Townhouse	6:12 Min, 12:12 Max	B D
Shophouse	9:12 Min, 14:12 Max	C E
Live-work/ Flex	6:12 Min, 12:12 Max	B D
Shop	9:12 Min, 14:12 Max	C E
Inn Building	6:12 Min, 12:12 Max	B D
Mixed-use Building	6:12 Min, 12:12 Max	B D
Fabrication Building	6:12 Min, 12:12 Max	B D
Civic Building	6:12 Min, 12:12 Max	B D

c. ROOF PITCH BY ACCESSORY BUILDING TYPE

Barn	9:12 Min, 14:12 Max	C E
Farmstand	9:12 Min, 14:12 Max	C E
Carriage House	9:12 Min, 14:12 Max	C E
Fabrication Shop	9:12 Min, 14:12 Max	C E
Accessory Shop	9:12 Min, 14:12 Max	C E

d. ROOF PITCH BY COMPONENT TYPE

Porch	3:12 Min, 12:12 Max	A D
Gallery	3:12 Min, 12:12 Max	A D
Side Wing	9:12 Min, 14:12 Max	C E
Rear Addition	9:12 Min, 14:12 Max	C E
Stoop	-	
Connector	-	
Cross Gable	9:12 Min, 14:12 Max	C E
Shed Dormer	-	
Window Dormer	3:12 Min, 14:12 Max	A E
Bay Window	3:12 Min, 14:12 Max	A E
Balcony	-	
Extended Shopfront	-	C D
Turret	-	
Arcade	-	
Porte-Cochere	3:12 Min, 9:12 Max	A C
Portico	3:12 Min, 9:12 Max	A C

Deck	-	
Tower	-	
Roof Deck	-	
Cupola	-	
Canopy	3:12 Min, 9:12 Max	A C

e. STANDARDS

1. Civic buildings are exempt from roof system regulation. The values presented in this table are guidelines only.
2. Rear additions may not exceed the roof pitch of the primary building to which they attach.

2. HIPPED ROOF

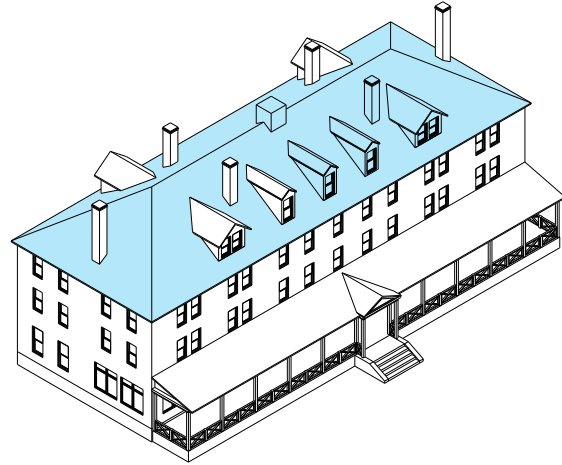
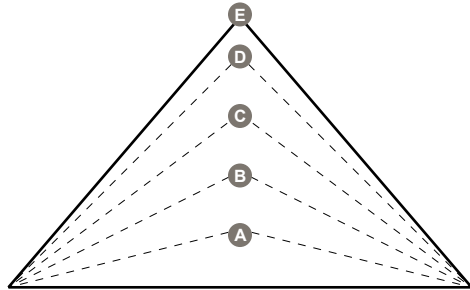

a. DESCRIPTION

A pitched roof with all sides inclined at the same slope, such that they meet symmetrically at a shared ridge beam or a point.

b. ROOF PITCH BY BUILDING TYPE

Cottage	6:12 Min, 12:12 Max	B D
House	6:12 Min, 12:12 Max	B D
Bungalow	-	
Duplex	6:12 Min, 12:12 Max	B D
Apartment House	6:12 Min, 12:12 Max	B D
Apartment Building	6:12 Min, 12:12 Max	B D
Townhouse	3:12 Min, 12:12 Max	A D
Shophouse	6:12 Min, 12:12 Max	B D
Live-work/ Flex	3:12 Min, 12:12 Max	A D
Shop	6:12 Min, 12:12 Max	B D
Inn Building	3:12 Min, 12:12 Max	A D
Mixed-use Building	3:12 Min, 12:12 Max	A D
Fabrication Building	3:12 Min, 12:12 Max	A D
Civic Building (1)	3:12 Min, 12:12 Max	A D

c. ROOF PITCH BY ACCESSORY BUILDING TYPE

Barn	-	
Farmstand	3:12 Min, 12:12 Max	A D
Carriage House	3:12 Min, 12:12 Max	A D
Fabrication Shop	3:12 Min, 12:12 Max	A D
Accessory Shop	3:12 Min, 12:12 Max	A D

d. ROOF PITCH BY COMPONENT TYPE

Porch	3:12 Min, 12:12 Max	A D
Gallery	3:12 Min, 12:12 Max	A D
Side Wing	3:12 Min, 12:12 Max	A D
Rear Addition	3:12 Min, 12:12 Max	A D
Stoop	-	
Connector	3:12 Min, 12:12 Max	A D
Cross Gable	-	
Shed Dormer	-	
Window Dormer	3:12 Min, 12:12 Max	A D
Bay Window	3:12 Min, 12:12 Max	A D
Balcony	-	
Extended Shopfront	-	A D
Turret	3:12 Min, 14:12 Max	A E
Arcade	3:12 Min, 12:12 Max	A D
Porte-Cochere	3:12 Min, 12:12 Max	A D
Portico	3:12 Min, 9:12 Max	A C
Deck	-	

Tower	3:12 Min, 12:12 Max	A D
Roof Deck	-	
Cupola	3:12 Min, 12:12 Max	A D
Canopy	3:12 Min, 12:12 Max	A D

e. STANDARDS

1. Civic buildings are exempt from roof system regulation. The values presented in this table are guidelines only.
2. Rear additions may not exceed the roof pitch of the primary building to which they attach.

3. MANSARD ROOF

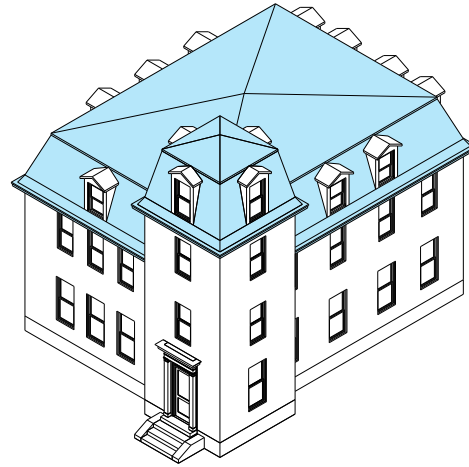
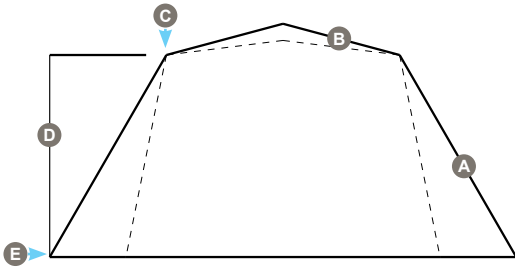

a. DESCRIPTION

A complex roof type consisting of a shallow sloped upper portion, and a steeper sloped lower portion.

b. ROOF PITCH BY BUILDING TYPE

Cottage	lower slope: 9:12 min, 60:12 max upper slope: 1.5:12 min, 3:12 max	A B
House	lower slope: 9:12 min, 60:12 max upper slope: 1.5:12 min, 3:12 max	A B
Bungalow	-	
Duplex	lower slope: 9:12 min, 60:12 max upper slope: 1.5:12 min, 3:12 max	A B
Apartment House	lower slope: 9:12 min, 60:12 max upper slope: 1.5:12 min, 3:12 max	A B
Apartment Building	lower slope: 9:12 min, 60:12 max upper slope: 1.5:12 min, 3:12 max	A B
Townhouse	-	
Shophouse	lower slope: 9:12 min, 60:12 max upper slope: 1.5:12 min, 3:12 max	A B
Live-work/ Flex	-	
Shop	-	
Inn Building	lower slope: 9:12 min, 60:12 max upper slope: 1.5:12 min, 3:12 max	A B
Mixed-use Building	lower slope: 9:12 min, 60:12 max upper slope: 1.5:12 min, 3:12 max	A B

Fabrication Building	-	
Civic Building (1)	lower slope: 9:12 min, 60:12 max upper slope: 1.5:12 min, 3:12 max	A B

c. ROOF PITCH BY ACCESSORY BUILDING TYPE

Barn	-	
Farmstand	-	
Carriage House	lower slope: 9:12 min, 60:12 max upper slope: 1.5:12 min, 3:12 max	A B
Fabrication Shop	-	
Accessory Shop	-	

d. ROOF PITCH BY COMPONENT TYPE

Porch	-	
Gallery	-	
Side Wing	lower slope: 9:12 min, 60:12 max upper slope: 1.5:12 min, 3:12 max	A B
Rear Addition	lower slope: 9:12 min, 60:12 max upper slope: 1.5:12 min, 3:12 max	A B
Stoop	-	
Hyphen	-	
Cross Gable	-	
Shed Dormer	-	
Window Dormer	-	

Bay Window	-	
Balcony	-	
Extended Shopfront	-	
Turret	lower slope: 9:12 min, 60:12 max upper slope: 1.5:12 min, 3:12 max	A B
Arcade	-	
Porte-Cochere	-	
Portico	-	
Deck	-	
Tower	lower slope: 9:12 min, 60:12 max upper slope: 1.5:12 min, 3:12 max	A B
Roof Deck	-	
Cupola	lower slope: 9:12 min, 60:12 max upper slope: 1.5:12 min, 3:12 max	A B
Canopy	-	

e. STANDARDS

1. Civic buildings are exempt from roof system regulation. The values presented in this table are guidelines only.
2. Rear additions may not exceed the roof pitch of the primary building to which they attach.
3. Mansard roofs must always set the chine **C** to be at least 8 ft but no more than 12 ft **D** higher than the eaves **E**.

4. GAMBREL ROOF

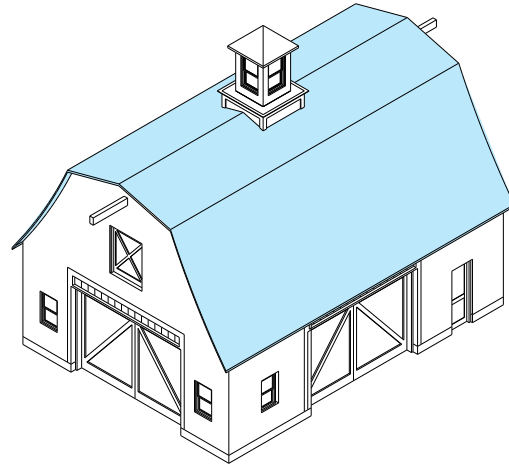
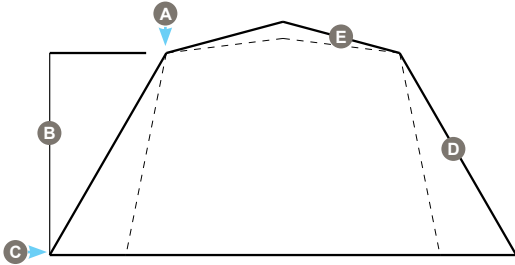

a. DESCRIPTION

A complex pitched roof with two sides, each of which has a shallower slope above the steeper one.

b. ROOF PITCH BY BUILDING TYPE

Cottage	-	
House	lower slope: 9:12 min, 60:12 max upper slope: 1.5:12 min, 3:12 max	D E
Bungalow	lower slope: 9:12 min, 60:12 max upper slope: 1.5:12 min, 3:12 max	D E
Duplex	lower slope: 9:12 min, 60:12 max upper slope: 1.5:12 min, 3:12 max	D E
Apartment House	lower slope: 9:12 min, 60:12 max upper slope: 1.5:12 min, 3:12 max	D E
Apartment Building	lower slope: 9:12 min, 60:12 max upper slope: 1.5:12 min, 3:12 max	D E
Townhouse	-	
Shophouse	lower slope: 9:12 min, 60:12 max upper slope: 1.5:12 min, 3:12 max	D E
Live-work/ Flex	-	
Shop	lower slope: 9:12 min, 60:12 max upper slope: 1.5:12 min, 3:12 max	D E
Inn Building	lower slope: 9:12 min, 60:12 max upper slope: 1.5:12 min, 3:12 max	D E

Mixed-use Building	lower slope: 9:12 min, 60:12 max upper slope: 1.5:12 min, 3:12 max	D E
Fabrication Building	lower slope: 9:12 min, 60:12 max upper slope: 1.5:12 min, 3:12 max	D E
Civic Building (1)	lower slope: 9:12 min, 60:12 max upper slope: 1.5:12 min, 3:12 max	D E

c. ROOF PITCH BY ACCESSORY BUILDING TYPE

Barn	lower slope: 9:12 min, 60:12 max upper slope: 1.5:12 min, 3:12 max	D E
Farmstand	lower slope: 9:12 min, 60:12 max upper slope: 1.5:12 min, 3:12 max	D E
Carriage House	lower slope: 9:12 min, 60:12 max upper slope: 1.5:12 min, 3:12 max	D E
Fabrication Shop	lower slope: 9:12 min, 60:12 max upper slope: 1.5:12 min, 3:12 max	D E
Accessory Shop	lower slope: 9:12 min, 60:12 max upper slope: 1.5:12 min, 3:12 max	D E

d. ROOF PITCH BY COMPONENT TYPE

Porch	-	
Gallery	-	
Side Wing	lower slope: 9:12 min, 60:12 max upper slope: 1.5:12 min, 3:12 max	D E

Rear Addition	lower slope: 9:12 min, 60:12 max upper slope: 1.5:12 min, 3:12 max	D E
Stoop	-	
Hyphen	lower slope: 9:12 min, 60:12 max upper slope: 1.5:12 min, 3:12 max	D E
Cross Gable	lower slope: 9:12 min, 60:12 max upper slope: 1.5:12 min, 3:12 max	D E
Shed Dormer	-	
Window Dormer	-	
Bay Window	-	
Balcony	-	
Extended Shopfront	-	
Turret	-	
Arcade	-	
Porte-Cochere	lower slope: 9:12 min, 60:12 max upper slope: 1.5:12 min, 3:12 max	D E
Portico	-	
Deck	-	
Tower	-	
Roof Deck	-	
Cupola	-	
Canopy	-	

e. STANDARDS

1. Civic building are exempt from roof system regulation. The values presented in this table are guidelines only.
2. Rear additions may not exceed the roof pitch of the primary building to which they attach.
3. Gambrel roofs must always set the chine **A** to be at least 8 ft but no more than 12 ft **E** higher than the eaves **C**.

5. SHED ROOF

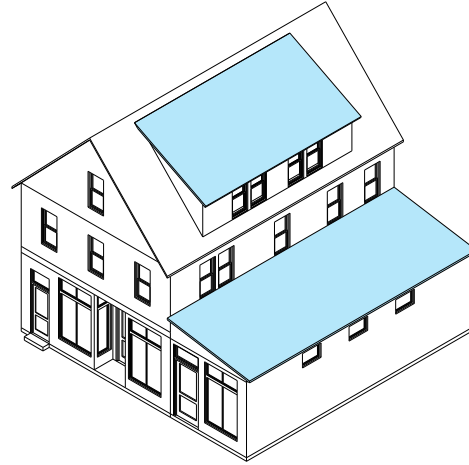
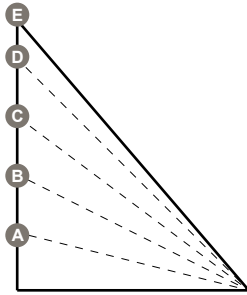

a. DESCRIPTION

A simple roof pitched in only one direction.

b. ROOF PITCH BY BUILDING TYPE

Cottage	-	
House	-	
Bungalow	-	
Duplex	-	
Apartment House	-	
Apartment Building	-	
Townhouse	3:12 Min, 6:12 Max	(A) (B)
Shophouse	-	
Live-work/ Flex	3:12 Min, 6:12 Max	(A) (B)
Shop	3:12 Min, 6:12 Max	(A) (B)
Inn Building	-	
Mixed-use Building	3:12 Min, 6:12 Max	(A) (B)
Fabrication Building	3:12 Min, 6:12 Max	(A) (B)
Civic Building (1)	3:12 Min, 6:12 Max	(A) (B)

c. ROOF PITCH BY ACCESSORY BUILDING TYPE

Barn	-	
Farmstand	3:12 Min, 6:12 Max	(A) (B)
Carriage House	-	
Fabrication Shop	3:12 Min, 6:12 Max	(A) (B)
Accessory Shop	3:12 Min, 6:12 Max	(A) (B)

d. ROOF PITCH BY COMPONENT TYPE

Porch	3:12 Min, 6:12 Max	(A) (B)
Gallery	3:12 Min, 6:12 Max	(A) (B)
Side Wing	3:12 Min, 6:12 Max	(A) (B)
Rear Addition	3:12 Min, 6:12 Max	(A) (B)
Stoop	3:12 Min, 6:12 Max	(A) (B)
Hyphen	3:12 Min, 6:12 Max	(A) (B)
Cross Gable	-	
Shed Dormer	3:12 Min, 6:12 Max	(A) (B)
Window Dormer	3:12 Min, 6:12 Max	(A) (B)
Bay Window	3:12 Min, 6:12 Max	(A) (B)
Balcony	-	
Extended Shopfront	3:12 Min, 6:12 Max	(A) (B)
Turret	-	
Arcade	3:12 Min, 6:12 Max	(A) (B)
Porte-Cochere	3:12 Min, 6:12 Max	(A) (B)
Portico	3:12 Min, 6:12 Max	(A) (B)

Deck	-	
Tower	-	
Roof Deck	-	
Cupola	-	
Canopy	3:12 Min, 6:12 Max	A B

e. STANDARDS

1. Civic buildings are exempt from roof system regulation. The values presented in this table are guidelines only.
2. Rear additions may not exceed the roof pitch of the primary building to which they attach.
3. When used on a component that is attaching to a building, shed roofs must always orient the ridge beam to the wall or roof it is attaching to.

6. FLAT ROOF

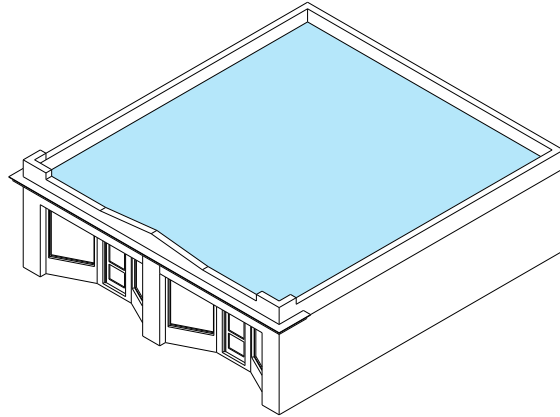
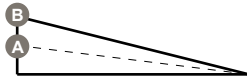

a. DESCRIPTION

A simple roof pitched very slightly in one or more directions, approximating a flat surface.

b. ROOF PITCH BY BUILDING TYPE

Cottage	-	
House	-	
Bungalow	-	
Duplex	-	
Apartment House	-	
Apartment Building	-	
Townhouse	1.5:12 min, 3:12 max	A B
Shophouse	-	
Live-work/ Flex	1.5:12 min, 3:12 max	A B
Shop	1.5:12 min, 3:12 max	A B
Inn Building	1.5:12 min, 3:12 max	A B
Mixed-use Building	1.5:12 min, 3:12 max	A B
Fabrication Building	1.5:12 min, 3:12 max	A B
Civic Building (1)	1.5:12 min, 3:12 max	A B

c. ROOF PITCH BY ACCESSORY BUILDING TYPE

Barn	-	
Farmstand	1.5:12 min, 3:12 max	A B
Carriage House	-	
Fabrication Shop	1.5:12 min, 3:12 max	A B
Accessory Shop	1.5:12 min, 3:12 max	A B

d. ROOF PITCH BY COMPONENT TYPE

Porch	1.5:12 min, 3:12 max	A B
Gallery	1.5:12 min, 3:12 max	A B
Side Wing	1.5:12 min, 3:12 max	A B
Rear Addition	1.5:12 min, 3:12 max	A B
Stoop	-	
Connector	1.5:12 min, 3:12 max	A B
Cross Gable	-	
Shed Dormer	-	
Window Dormer	-	
Bay Window	1.5:12 min, 3:12 max	A B
Balcony	-	
Extended Shopfront	1.5:12 min, 3:12 max	A B
Turret	1.5:12 min, 3:12 max	A B
Arcade	1.5:12 min, 3:12 max	A B
Porte-Cochere	1.5:12 min, 3:12 max	A B
Portico	1.5:12 min, 3:12 max	A B

Deck	-	
Tower	1.5:12 min, 3:12 max	A B
Roof Deck	-	
Cupola	1.5:12 min, 3:12 max	A B
Canopy	1.5:12 min, 3:12 max	A B

e. STANDARDS

1. Civic buildings are exempt from roof system regulation. The values presented in this table are guidelines only.
2. Rear additions may not exceed the roof pitch of the primary building to which they attach.
3. All slopes for flat roofs should defer to local building code regarding minimum slopes for a specified roofing system.

Absolute Height:

Height as measured from the surface of the ground to the highest point on a building.

Accessory Building:

See Building, Accessory.

Accessory Unit:

An additional permitted residential or commercial unit located in a component of a primary building or in an accessory building.

Alley:

A thoroughfare typically located internal to a block that provides access to the side or rear of lots and onto which no lot directly fronts. Alleys typically provide access to service areas, parking, and accessory buildings and may contain utility easements.

Attached:

An object may be said to be attached to another when their outer surfaces are permanently in direct contact, or when they share part of their structural system.

Attic:

The non-habitable interior space located directly under a pitched roof of a building.

Average Ground Level:

The mean (average) ground level at the corners of the main body of a building type.

Awning:

A wall mounted, pitched, fabric covering extending from a building to provide shade and weather protection for pedestrians.

Bay:

An area of a facade between two buttresses, pilasters, columns, piers, or other equivalent architectural features.

Bracket:

A visual and/or structural support, typically made of metal or wood, projecting from a building face to bear the weight or visually support a building element.

Building, Accessory:

A second, and typically smaller building, typically located on a lot with a primary building, often times toward the rear of the lot, and sometimes connected to the primary building.

Building, Primary:

A permitted building capable of occupying a lot as the sole structure, as distinct from accessory buildings and additional structures which are dependent on a primary building.

Building Element:

Any part of a building, including the main building mass, components, and accessory buildings.

Building Face:

Any exterior wall of a Building.

Building Height:

The measurement of building height by stories, where each full story above average ground level is counted as 1 story. For buildings with a pitched roofs, habitable space is allowed within the pitch and is not considered a full story.

Building Mass:

See Main Building Mass.

Building Type:

A classification or kind of structure characterized and differentiated by its massing, composition, use, features, and placement on a lot.

Carriage House:

An enclosed area integral to a primary building or accessory building that provides space for parking or storage of vehicles. Not synonymous with the parking garage building type.

Carriage House Doors:

Lifting, sliding, or swinging doors that open into an interior space used for vehicular parking, storage, retail sales, fabrication, or other uses.

Civic Space:

An outdoor open space designed to support social and recreational activities.

Clearance:

The height above the sidewalk or other surface, to the bottom edge of an object or building component.

Clear Height:

The vertical distance between the underside of an overhanging building element and the horizontal surface below, free from obstruction.

Component:

One of the elements that make up a building, the other being the main building mass. Components are comprised of smaller attachments to the main building mass and provide architectural articulation and additional usable space.

Corbel:

Any bracket, especially one of brick or stone, that typically protrudes only slightly from the face of a building.

Detached:

A dwelling that is physically separated from any other structure or structures except accessory buildings.

Eave:

The soffit resulting from the junction of a building wall and an overhanging roof.

Elevation:

The vertical distance between the average ground plane and the top of the finished first floor of a building.

Enclose(d):

To fill in the spaces between structural supports with latticework, walls, windows, or other non-structural wall covering to increase the usability of an outdoor space.

First Floor Elevation:

The height from the average ground level to the surface of the first full floor, measured at the primary front facade of the building.

Fully Enclose(d):

To fill the space between structural supports with walls or windows.

Element:

See Building Element.

Encroach:

To break the plane of a vertical or horizontal regulatory limit with a structural element, so that it extends into a Setback, above a height limit, or over the sidewalk of a public right-of-way.

Encroachment:

Any structural element that breaks the plane of a vertical or

horizontal regulatory limit, extending into a setback, above a height limit, or the breaking of such limit by a structural element.

Façade:

The exterior wall of a building oriented in whole or in part toward a thoroughfare, civic space, or on-site civic space (not including alleys).

Face:

The surface of a structure or element, especially one that is presented to the view.

Fenestration:

The arrangement, proportioning, and design of openings on every exterior wall of a building, including windows and doors but excluding entrances and doors for parking, loading, and service facilities. If a Carriage House door is more than 50% glass, it is counted as a window and door. (see Diagram 1 Fenestration)

Fenestration, Ground Story

The percentage of openings present on a building's ground floor. (see Diagram 1 Fenestration)

Fenestration, Upper Story

The percentage of openings on the upper stories, each considered independently. (see Diagram 1 Fenestration)

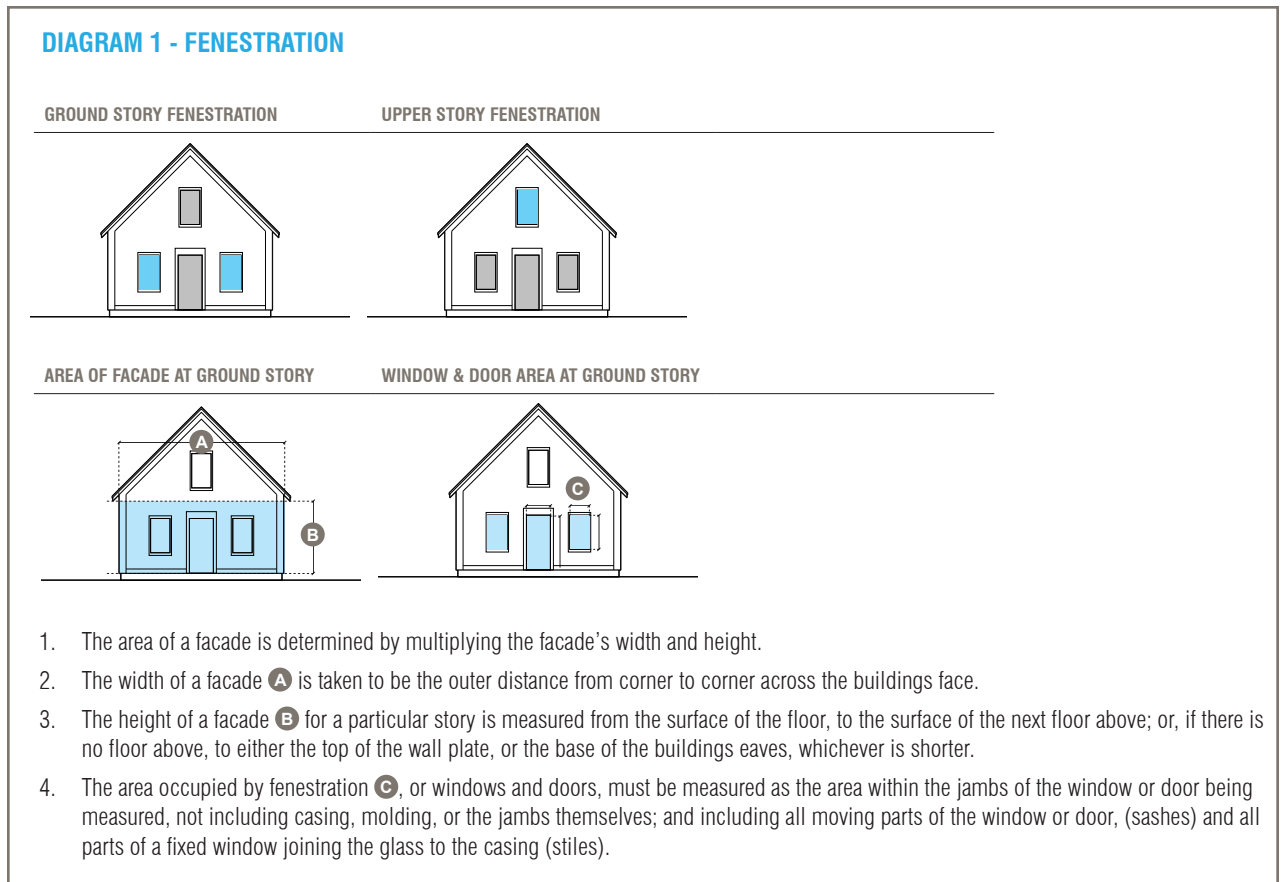

First Floor:

The lowest floor of a building that is not considered a basement.

First Floor Elevation

The height from the average ground level to the surface of the first full floor, measured at the primary front facade of the building.

Flat Roof:

see Roof, Flat.

Floor Area, Gross:

The sum area of all floors or accessible levels of a building as measured to the perimeter of the exterior faces of the walls with no deduction for corridors, stairs, closets, thickness of walls, columns or other features.

Floor Plate:

The total gross floor area of a single story of a building, excluding all unenclosed components of a building.

Forecourt:

A landscaped, semi-public area, open to the sky, formed by a recess in a portion of a building facade.

Front (noun):

A condition in which a building is required to be parallel or perpendicular with a frontage line.

Front (verb):

A condition in which a building is required to be parallel or perpendicular with a frontage line.

Front Setback:

The distance from the front lot line to the point where any structure may be constructed.

Frontage:

The land that lies adjacent to a thoroughfare, right-of-way, easement, civic space, or waterbody, or the space between a building. Building facades that face onto primary and secondary frontages define the public realm and are therefore more regulated than the buildings oriented toward side and rear lot lines.

Frontage Line:

A lot line bordering a thoroughfare, right-of-way, easement, civic space, or waterbody.

Frontage, Primary:

The primary frontage is the frontage that abuts the primary thoroughfare or, if there is no thoroughfare, it is the frontage that abuts a civic space, right-of-way, or easement.

Frontage, Secondary:

On corner lots, the frontage that is oriented toward the thoroughfare that is not the primary thoroughfare.

Front Setback, Primary:

The setback required along a primary frontage.

Front Setback, Secondary:

The setback required along a secondary frontage.

Frontage Zone:

The area between the front lot line of a property and the first 20 ft of a primary building. The frontage zone applies along both the primary and secondary frontages, and does not apply to alleys. In the case that a lot is undeveloped, the frontage zone is the area between the front lot line of a property and 30 ft into the site.

Grade:

The natural finished ground level of land ground level, or the elevation, at any given point.

Ground Plane:

The surface of the ground.

Height:

The distance between two points along a vertical plane.

Informal Building:

Informal buildings are light-impact, temporary, or small buildings, that are typically not connected to utilities and oftentimes don't have a permanent foundation.

Intersect:

A condition where one element touches and/or overlaps with another element.

Integral:

A condition that refers to one element being located within another.

Integrated:

See Integral.

Length:

In a three-dimensional measurement system, length is a horizontal measurement, distinct and longer than width.

Liner Building:

A standalone building or a portion of a building located along a frontage that is meant to shield a storage, parking, or utility area from view and create an active, habitable space to make a street or public space feel more safe and inviting.

Lot, Theoretical:

A potential lot created by theoretical lot lines demarcated on a plan to show and determine conformance with this Ordinance, without the act of legal subdivision. Syn: Theoretical Lot Lines.

Lot Line, Theoretical:

Lot lines demarcated on a plan to show and determine conformance with this Ordinance. Theoretical lot lines do not require an act of legal subdivision.

Main Building Mass:

The volume of a primary or accessory building as defined by the dimensional standards for building type and onto which components and roofs may attach.

Patio:

A hard-surfaced, landscaped space constructed at ground level, usually directly adjacent to a building. A patio is constructed with a finished walking surface laid or poured directly on finished grade. A patio has no permanent roof coverings.

Permitting Authority:

A person or board granted the authority to conduct project review and approval, in accordance with this Ordinance.

Pier:

A solid support designed to sustain vertical pressure, such as used in a section of a wall between windows or other adjacent openings or as structural member used in the construction of building foundations.

Platform:

An elevated flat structure meant to support the weight of people at or above the plane of the ground.

Primary Entrance:

The main point of access for pedestrians into a building, upper story use, or first floor tenant space.

Primary Ridge Beam:

The highest framing member of a pitched roof to which all rafters attach.

Project(ed):

When a building element extends perpendicular and away from the building face to which it is attached.

Rafter:

One of several internal beams extending from the eaves to the peak of the roof and constituting its frame.

Roof Line:

The highest point on any building or structure where an exterior wall or parapet wall encloses roof or floor area, including floor area provided for housing mechanical equipment.

Setback:

The horizontal distance required between the closest exterior wall of a building or parking and a specified element, such as a lot line, easement, or waterbody, measured perpendicularly. This area must be maintained clear of permanent structures with the exception of allowed encroachments.

Shopfront:

A first floor building facade, where substantial glazing is required, and the building entrance is located at the grade of the sidewalk or adjacent walkway.

Soffit:

The flat underside of an overhanging building element such as eaves or cornices.

Stallriser:

A section of wall below a storefront display window.

Story:

An occupiable floor of a building as distinct from the area contained under the pitch of a roof or a basement.

Streetwall:

A condition where buildings, through their consistent arrangement along a street, create the impression of forming a wall. While the buildings can be separated, a streetwall is predicated on the buildings all having a similar front setback that is in close proximity to the street or civic space.

Streetwall, Continuous:

A streetwall condition comprised by buildings that are predominantly attached on the sides and that all have a consistent front setback directly on the property line.

Terraced:

An area of sloped land that has been made into a series of level areas, resembling steps.

Top Plate:

The topmost horizontal, load-bearing member in a framed wall system.

Unit:

A single, internally connected space that comprises a building or a part of a building that can be occupied by any one of the use categories included in this Ordinance.

Vertical Plane:

A flat surface perpendicular to the ground or horizontal plane.

PAGE LEFT INTENTIONALLY BLANK